

EXTRA

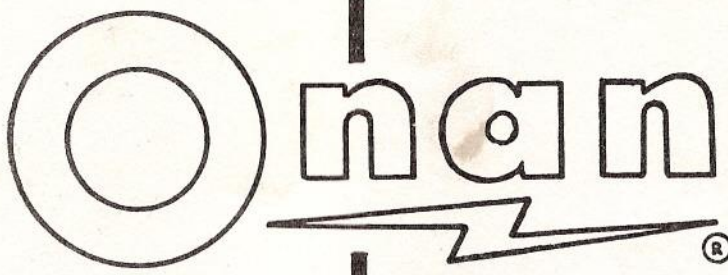

**SERVICE  
AND  
PARTS CATALOG**

**SERIES  
NB**

**INDUSTRIAL ENGINES**

**MODELS**

- NB- MS/1846A**
- NB- MS/1847A**

**ONAN**

1400 73RD AVENUE N. E. • MINNEAPOLIS, MINNESOTA 55432  
*A DIVISION OF STUDEBAKER CORPORATION*  
IN CANADA: Guelph, Ontario • N.Y. INTERNATIONAL OFFICE: Empire State Bldg.

# ONAN INDUSTRIAL ENGINES

## **NB** **SERIES**



### MODELS

**NB- MS/1846A**

**NB- MS/1847A**

#### TABLE OF CONTENTS

TITLE	PAGE
General Information .....	2
Operation .....	3
Adjustments .....	5
General Maintenance .....	8
Engine Troubleshooting .....	10
Assembly Torques and Clearances .....	11
Fuel System .....	12
Valve System .....	15
Engine Disassembly .....	17
Starting System .....	22
Parts Catalog .....	25

#### GENERAL INFORMATION

THIS MANUAL PROVIDES INFORMATION FOR PROPER OPERATION, MAINTENANCE, AND SERVICE PROCEDURES; ALSO PARTS CATALOG.

WE SUGGEST THIS BOOK BE KEPT HANDY FOR READY REFERENCE WHEN NECESSARY, EITHER FOR ORDERING PARTS OR MAKING ADJUSTMENTS.

**IMPORTANT...RETURN WARRANTY CARD ATTACHED TO UNIT**



# GENERAL INFORMATION

## TRACTOR - ENGINE MODEL REFERENCE

Tractor Model No.	ONAN Engine Model No.
424 (10 h.p.)	NB-MS/1846
430 (12 h.p.)	NB-MS/1847

Some instructions in this manual refer to specific models of industrial engines. Identify the model by referring to the *MODEL AND SPEC.* (specification) *NO.* as shown on the unit nameplate.

### How to interpret MODEL and SPEC. NO.

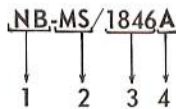

1. Factory code for general identification purposes.
2. Specific Type:  
*S-MANUAL* starting with stub shaft power take off.  
*MS-ELECTRIC* starting with stub shaft, starter and generator.
3. Factory code for optional equipment supplied.
4. Specification (Spec. Letter) advances with factory production modification.

## SPECIFICATIONS

### TWO MODELS:

NB-MS/1846	10 HP
NB-MS/1847	12 HP
Number Cylinders	1
Displacement (cu. in.)	30.0
Cylinder bore	3 9/16
Piston Stroke	3
Horsepower (at 3600 RPM)	10 & 12
Compression ratio	7:1
Oil capacity	2 quarts

### ONAN MANUFACTURER'S WARRANTY

The Manufacturer warrants, to the original user, that each product of its manufacture is free from defects in material and factory workmanship if properly installed, serviced and operated under normal conditions according to the Manufacturer's instructions.

Manufacturer's obligation under this warranty is limited to correcting without charge at its factory any part or parts thereof which shall be returned to its factory or one of its Authorized Service Stations, transportation charges prepaid, within one year after being put into service by the original user, and which upon examination shall disclose to the Manufacturer's satisfaction to have been originally defective. Correction of such defects by repair to, or supplying of replacements for defective parts, shall constitute fulfillment of all obligations to original user.

This warranty shall not apply to any of the Manufacturer's products which must be replaced because of normal wear, which have been subject to misuse, negligence or accident or which shall have been repaired or altered outside of the Manufacturer's factory unless authorized by the Manufacturer.

Manufacturer shall not be liable for loss, damage or expense directly or indirectly from the use of its product or from any other cause.

The above warranty supersedes and is in lieu of all other warranties, expressed or implied, and of all other liabilities or obligations, on part of Manufacturer. No person, agent or dealer is authorized to give any warranties on behalf of the Manufacturer nor to assume for the Manufacturer any other liability in connection with any of its products unless made in writing and signed by an officer of the Manufacturer.

---

# OPERATION

---

## BEFORE STARTING

Check the engine to make sure it has been filled with oil and fuel. Note recommendations below.

**Crankcase Oil:** Use a good-quality detergent oil that meets the API (American Petroleum Institute) service designations, MS, MS/DG, or MS/DM. Recommended SAE oil numbers for expected ambient temperatures are as follows:

### OIL CAPACITY - 2 QTS.

Below 30°F	SAE 5W20
Above 30°F	SAE 30

Do not use service DS oil. Do not mix brands or grades. Refer to Maintenance Section for recommended oil changes and complete lubricating oil recommendations.

**Recommended Fuel:** Use clean, fresh, regular grade, automotive gasoline. Do not use highly leaded premium types. Never fill the tank when the engine is running; leave some fuel expansion space.

## STARTING

Refer to tractor manual for location, setting, and operation of electric start, choke, and throttle controls.

If the engine fails to start after cranking several times, rust inhibitor oil injected into the cylinder at the factory may have fouled the spark plug. Remove the plug and clean in non-flammable solvent. Dry thoroughly and re-install. Engine should now start without difficulty. Heavy exhaust smoke may be noticed when engine is first started. This is normal and is caused by the inhibitor oil burning off.

## STOPPING

Refer to tractor manual for location and operation of "Stop" control.

## BREAK-IN PROCEDURE

No matter how carefully engine parts are manufactured or expertly assembled, there are always microscopic variations in fit between metal parts such as pistons, rings, main and connecting rod bearings.

Break-in or ideal fitting of all internal moving metal parts can best be achieved by maintaining proper cooling and correct lubrication during the running-in period. Break-in can take as little as ten operating hours or it may take many hundreds of hours. Extended periods of very heavy engine loading during this initial service

period can cause severe cylinder scoring or bearing galling. On the other hand extended periods of very light loading during initial break-in may cause cylinder wall glaze and/or poor piston ring seating. The tractor should be run at about half load for the first three hours with intermittent periods of full load to control engine break-in. Engine parts damage can also be caused by using the wrong type and viscosity oil and high engine operating temperatures during break-in.

All engines use more oil than normal during the first hours of operation. As internal moving parts are run-in by controlled operation, oil consumption should gradually decrease until the rate of consumption is stabilized. All engines use some oil even when in perfect condition and properly broken-in. Oil consumption varies according to engine design, engine (piston) speed, size of engine, type of oil, oil viscosity, length of operating periods, operating temperatures, engine loading, etc. As engine operation is continued, clearance between moving parts increase slightly due to normal wear of piston rings, cylinder walls, valve guides, oil seals, etc. After many hours operation, these clearances increase until oil consumption may be excessive and engine parts have to be replaced and/or refitted.

Engines manufactured by Onan can be loaded to full nameplate horsepower rating (not until they bog down) as soon as they are put into operation. However, it is recommended that during the first few hours of operation that full load be applied only intermittently. Proper loading helps seat piston rings and brings oil consumption to normal in the shortest time.

During break-in, check oil level at least every eight (8) operational hours. Add oil if the level is at low on the dipstick. Never over-fill. This may cause oil to foam and enter the breather system.

Drain the initial oil fill after 40 hours of operation while the engine is hot. Oil change at 20 hours is recommended after operation in extremely dirty or dusty conditions.

Controlled break-in with proper oil and a conscientiously applied maintenance program will help assure satisfactory service for many hours from your Onan engine.

## OUT-OF-SERVICE PROTECTION

Protect an engine that is to be out-of-service for more than 30 days as follows:

1. Run engine until thoroughly warm.



2. Turn off fuel supply and run until engine stops.
3. Drain oil from oil base while still warm. Refill and attach a warning tag stating oil viscosity used.
4. Remove spark plug. Pour 1 oz. (two tablespoons) of rust inhibitor (or SAE #50 oil) into the cylinder. Crank engine over a few times. Install spark plug.
5. Service air cleaner.
6. Clean governor linkage and protect by wrapping with a clean cloth.
7. Plug exhaust outlet to prevent entrance of moisture, dirt, bugs, etc.
8. Wipe entire unit. Coat rustable parts with a light film of grease or oil.
9. Provide a suitable cover for the entire unit.
10. If battery is used, disconnect and follow standard battery storage procedure.

#### **HIGH TEMPERATURES**

1. See that nothing obstructs air flow to-and-from the plant.
2. Keep cooling fins clean. Air housing should be properly installed and undamaged.

#### **LOW TEMPERATURES**

1. Use correct SAE No. oil for temperature conditions. Change oil only when engine is warm. If an unexpected temperature drop causes an emergency, move the unit to a warm location or apply heat externally until oil flows freely.
2. Use fresh fuel. Protect against moisture condensation.
3. Keep fuel system clean, and batteries in a well charged condition.

#### **DUST AND DIRT**

1. Keep unit clean. Keep cooling system clean.
2. Service air cleaner as frequently as necessary.
3. Change oil oftener under dusty conditions.
4. Keep oil and gasoline in dust-tight containers.
5. Keep governor linkage clean.

#### **HIGH ALTITUDE**

For operation at altitudes of 2500 feet above sea level, close carburetor main jet adjustment slightly to maintain proper air-to-fuel ratio (refer to the *Adjustments Section*). Maximum power will be reduced approximately 4% for each 1000 feet above sea level, after the first 1000 feet.

# ADJUSTMENTS

## ADJUSTMENTS

### CARBURETOR

The carburetor (Fig. 1) has a main fuel (high speed) adjustment (needle A) and a fuel idle adjustment (needle B). The main adjustment (needle A) affects operation under heavy load conditions. Idle adjustment affects operation at light or no load. Under normal circumstances, factory carburetor adjustments should not be disturbed. If the adjustments have been disturbed, turn needles off their seats, 1 to 1½ turns to permit starting, then, re-adjust them for smooth operation.

**CAUTION** Forcing the needle against its seat will damage it. The needle does not completely shut off fuel when turned fully in.

Before final adjustment, allow the engine to warm up. Make the idle adjustment under no load. Open the main jet until the engine runs smooth under acceleration with no load. Slightly more fuel may be needed (open about ¼ turn further) when sudden load is applied.

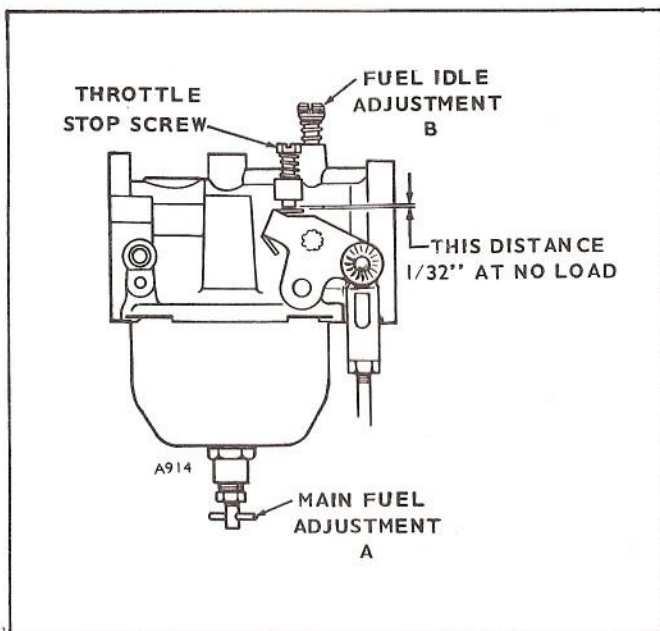

FIGURE 1. CARBURETOR ADJUSTMENT

Set the throttle stop screw (located on carburetor throttle lever) with no load connected and while running at a low rated speed setting. Turn the screw to give 1/32" clearance between the screw and pin (Fig. 1).

If the engine develops a "hunting" condition (alternate increase and decrease of engine speed) try correcting by opening the main adjusting needle a little more. Do

not open more than ½ turn beyond the maximum point of power. If this does not correct the condition, follow the instructions for regulating the sensitivity of the governor under GOVERNOR ADJUSTMENT.

### BATTERY CHARGE CIRCUIT

The battery charge voltage is regulated by solid state rectifiers within the regulator mounted on the dash panel. At full engine RPM the charge rate is approximately 10 amps. At idle speed, or about 1000 RPM, the rate is 2-3 amps. Since there is no adjustment in the regulator, maintenance is minimal with the exception of keeping the heat sink fins clean at all times.

### GOVERNOR ADJUSTMENT

Engine speed is governor-controlled, and preset at the factory. Proper governor adjustment is one of the most important factors in maintaining the power and speed desired from the engine.

These engines are adapted for use where a wide range of speed settings is desired. Engine speed is controlled at any given point between minimum and maximum by simply shifting the throttle lever on the dash panel until the desired speed is reached.

The design of the variable speed governor gives an automatic decrease in sensitivity when the speed is increased and the result is good stability at all speeds.

Before making governor adjustment, run the engine about 15 minutes to reach normal operating temperature. If the engine is being run with the throttle wide open, either the governor is not properly adjusted or the engine is overloaded. It is difficult to determine if after long usage the governor spring has become fatigued. If, after properly making all other adjustments, the regulation is still erratic, install a new spring (Fig. 2).

A reliable instrument for checking engine speed is required for accurate governor adjustment. Engine speed can be checked with a tachometer.

Check the governor arm, linkage, throttle shaft, and lever for binding condition or excessive slack and wear at connecting points. A binding condition at any point will cause the governor to act slowly and regulation will be poor. Excessive looseness will cause a hunting condition and regulation will be erratic. Work the arm back and forth several times by hand while the engine is idle. If either of these conditions exist, find out where the trouble lies and adjust or replace parts as needed.



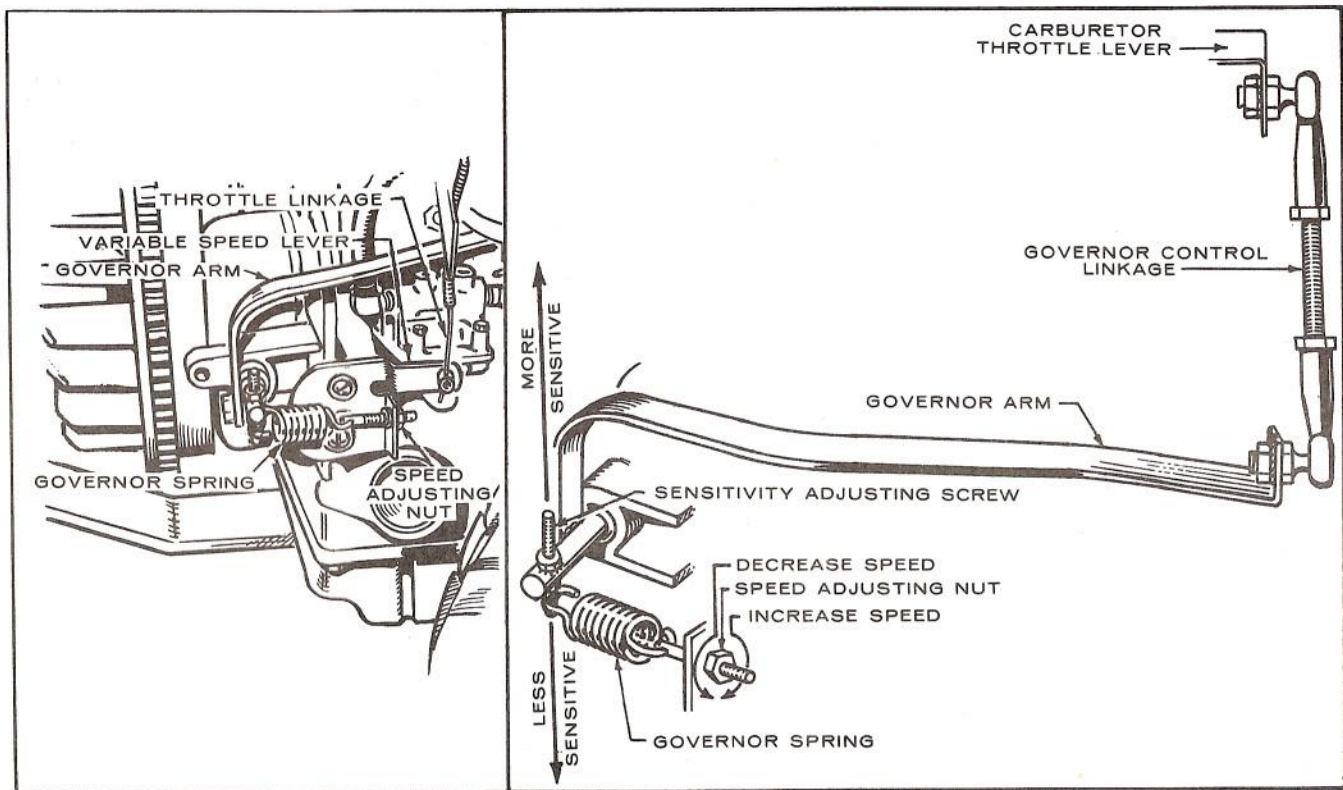

FIGURE 2. GOVERNOR ADJUSTMENT

**Linkage:** The engine starts at wide open throttle. The length of the linkage connecting the governor arm to the throttle arm is adjusted by rotating the ball joint. Adjust length so that with the engine stopped and tension on the governor spring, the stop screw on the carburetor throttle lever is  $1/32''$  from stop pin. (Fig. 1) This setting allows immediate control by the governor after starting and synchronizes travel of the governor arm and the throttle shaft.

**Procedure:** This gives the procedure only briefly. Refer to the details on each subject herein.

1. Adjust the carburetor main jet for the best fuel mixture at full load operation.
2. Adjust the carburetor idle needle with no load connected.
3. Adjust the length of the governor linkage.
4. Check the governor linkage and throttle shaft for binding or excessive looseness.
5. Adjust the governor spring tension for nominal engine speed at no-load operation.
6. Check the rpm drop between no-load and full-load operation and adjust the governor sensitivity as needed.
7. Recheck the speed adjustment.
8. Set the carburetor throttle stop screw.

Adjust the throttle stop screw on the carburetor to allow a recommended minimum idling speed of 800-1000 rpm. (A lower minimum does not assure smooth operation under load.)

Approximately 3000 rpm is the recommended maximum full load speed for continuous operation. The speed must agree with the load requirements.

**Speed Adjustment:** The speed at which the engine operates is determined by the tension applied to the governor spring. Increasing spring tension increases engine speed. Decreasing spring tension decreases engine speed. The no-load speed of the engine should be slightly higher than the speed requirements of the connected load.

If a speed adjustment is needed, turn the speed adjusting nut in to increase the speed or out to decrease the speed (Fig. 2).

Adjust the tension of the governor spring for minimum speed. Adjust the throttle linkage so that shifting of the throttle speed lever will give a desired range of speeds. First, shift the lever to minimum (slow) position and with no load connected, adjust the spring tension for about 800-1000 rpm.

Adjust the sensitivity while operating at minimum speed to attain the smoothest no load to full load operation as follows:

The sensitivity of the governor depends upon the position of the arm end of the governor spring. A threaded stud on the governor arm provides for adjustment. To increase sensitivity, move the governor spring toward the governor shaft by loosening the upper locknut on the threaded stud and tightening the lower nut. To decrease sensitivity, reverse the procedure.

A too-sensitive setting will result in a surging speed (hunting) condition, an alternate increase and decrease in engine speed. An opposite setting will result in too much speed variation between no load and full load conditions. Thus, the correct position of the governor spring will result in the most stable speed regulation without causing a surge condition.

Always recheck the speed adjustment after a sensitivity adjustment. Increasing sensitivity will cause a slight decrease in speed and will require a slight increase in the governor spring tension.



# GENERAL MAINTENANCE

## AIR CLEANER

The NB series engine is equipped with a paper cartridge, automotive type air cleaner (Fig. 3). Under normal usage the cleaner should be changed every 200 hours. Extremely dusty conditions may require a change every 50 hours. The cleaner should be inspected more frequently, especially if the engine appears to be losing power or idles roughly. If the cleaner element is dirty, it may be cleaned by tapping gently on a flat surface. When cleaning, do not dent the plastic sealing surfaces.

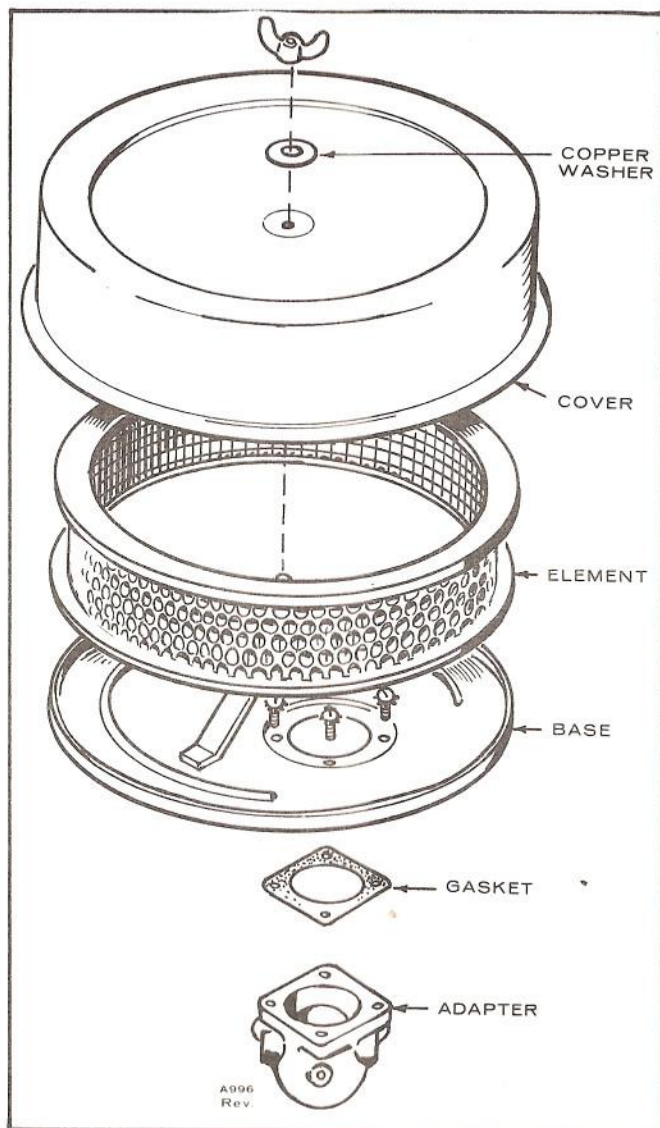

FIGURE 3. AIR CLEANER ASSEMBLY

Wipe the sealing surfaces and the air cleaner pan and cover clean before reassembling. When replacing the wing nut don't forget the copper washer. Tighten the wing nut finger tight only.

## CRANKCASE OIL

Oil capacity is 2 U.S. quarts. Fill to the *full* mark on oil indicator. Use a good quality detergent oil classified for service MS or MS/DG. Do not use service DS oil at any time. Use the proper SAE number of oil for the expected temperature conditions. Do not mix brands or grades. Extremely dusty or low temperature conditions require oil change at 20 hrs.

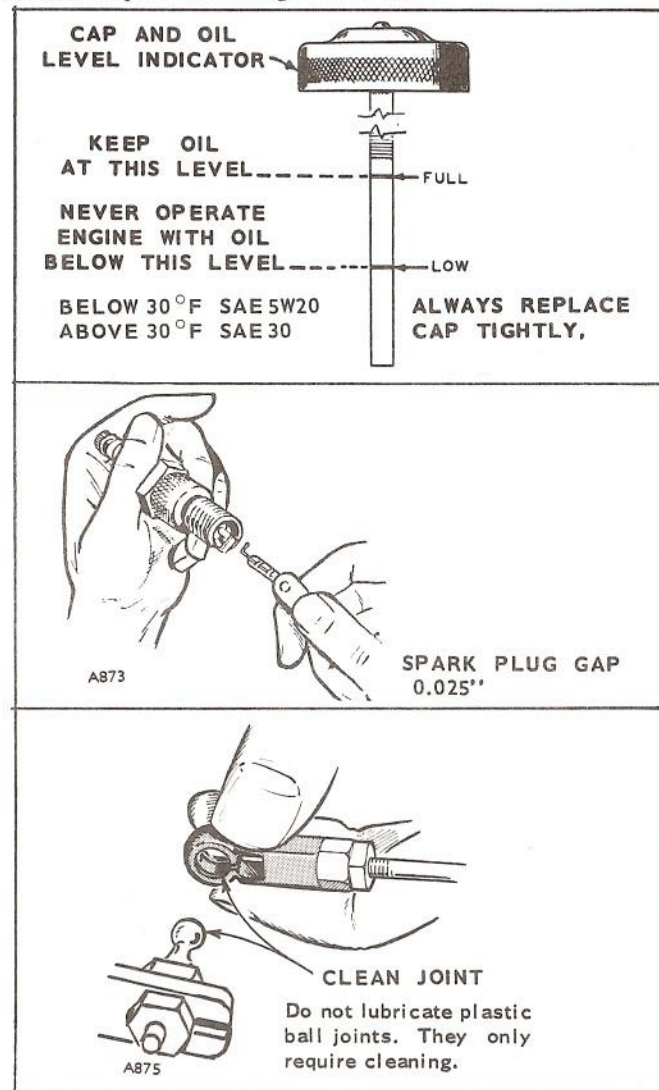

FIGURE 4. MAINTENANCE PROCEDURES

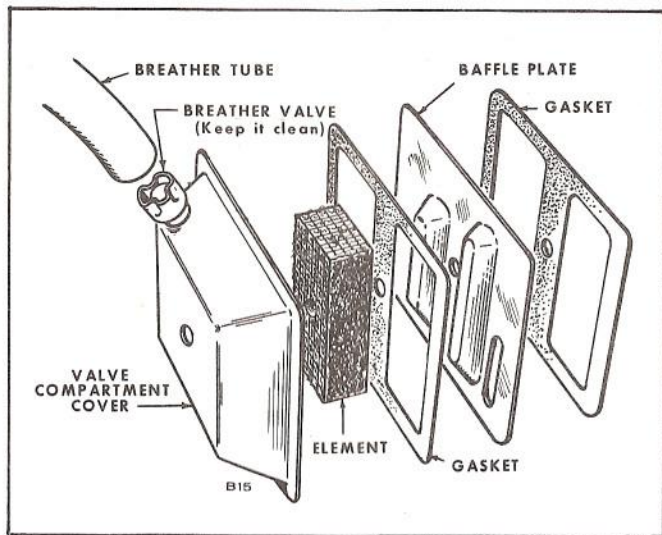

FIGURE 4A. MAINTENANCE PROCEDURES

### BREATHER VALVE

Remove the hose from the breather valve at the valve compartment cover. Wash the valve and filter in kerosene or other suitable solvent. Dry and replace. The valve must work free and the hose must not be restricted to prevent expelled air from re-entering the crankcase. Install parts removed with new gaskets.

**CAUTION** When reinstalling breather assembly, make sure the oil return hole in the lower right hand corner of the baffle plate is not covered by the gaskets.

### MAINTENANCE SCHEDULE

Use this factory recommended maintenance schedule (based on favorable operating conditions) to serve as a guide to get long and efficient unit life. Neglecting routine maintenance can result in failure or permanent damage to the unit. Maintenance is divided into two categories: (1) *operator maintenance*—performed by the operator and (2) *critical maintenance* performed by qualified service personnel (*Onan dealer*).

#### OPERATOR MAINTENANCE SCHEDULE

MAINTENANCE ITEMS	OPERATIONAL HOURS			
	8	40	100	200
Inspect Unit	x			
Check Fins For Dirt	x			
Check Oil Level	x			
Check Air Cleaner		x		
Clean Governor Linkage		x		
Check Spark Plug			x	
Change Crankcase Oil		x		
Clean Crankcase Breather				x
Clean Fuel System				x
Check Battery				x

x| - Perform more often in extremely dusty conditions.

#### CRITICAL MAINTENANCE SCHEDULE

MAINTENANCE ITEMS	OPERATIONAL HOURS		
	200	400	1000
Remove Carbon & Lead		x	
Check Valve Clearance		x	
Clean Carburetor		x	
*Clean Engine	x		
Remove & Clean Oil Base		x	
Grind Valves (if required)		x	
General Overhaul(if required)			x

\* - Do not allow grass cuttings, leaves, etc. to accumulate on the engine, especially between the cylinder head fins or in the governor control area. Make frequent inspections and perform a thorough cleaning at the end of the mowing and plowing season.

For any abnormalities in operation, unusual noises from engine or accessories, loss of power, overheating, etc., contact your Onan dealer.



# ENGINE TROUBLESHOOTING

OPERATOR'S TROUBLE-SHOOTING GUIDE for ONAN GASOLINE ENGINES (Air Cooled)		TROUBLE	CAUSE														
			Hard Starting or Failure to Start	Starter Motor Doesn't Turn	Engine Misfires	Speed Too High	Speed Too Low	Hunting Condition	No Governor Control	Poor Sensitivity	Excessive Oil Consumption	Excessive Fuel Consumption	Engine Backfires at Carburetor	Engine Overheats	Mechanical Knocks	Black Smoky Exhaust	Blue Smoky Exhaust
COOLING SYSTEM	Blown Head Gasket	●	●														
	Overheating									●			●	●			
	Dirt on Cooling Fins												●	●			
	Inadequate Air Circulation (Ventilation)									●							
FUEL SYSTEM	Out of Fuel, or Shut-off Valve Closed	●															
	Poor Quality Fuel	●	●								●				●		
	Dirty Fuel Filter	●	●	●													
	Fuel Line Leaks	●	●				●										
	Mixture Too Rich	●	●	●							●						
	Mixture Too Lean	●	●											●			
	Engine Flooded	●											●				
	Run for Long Periods of Time at No Load		●														
Restricted Air Intake, Dirty Air Filter	●	●									●						
GOVERNOR SYSTEM	Linkage Loose or Disconnected								●								
	Linkage Binding					●	●	●									
	Excessive Wear in Linkage					●	●	●									
	Incorrect Governor Adjustment				●	●		●									
	Spring Sensitivity Too Great				●	●											
LUBRICATION SYSTEM	Low Oil Supply													●	●		
	Excess Oil in Crankcase										●						●
	Oil Leaks From Engine Base or Connections										●						
	Crankcase Oil Too Light or Diluted										●			●	●		●
	Crankcase Oil Too Heavy	●															
STARTING SYSTEM AND IGNITION SYSTEM	Battery Discharged or Defective	●	●														
	Loose Battery Connections	●	●														
	Load Connected When Starting	●															
	Open Solenoid	●	●														
	Defective Starter	●	●														
	Wrong Plug or Point Setting	●		●													
	Incorrect Timing	●		●								●		●	●	●	●
	Spark Too Far Advanced													●	●		

# ASSEMBLY TORQUES AND CLEARANCES

Refer to the Trouble Shooting section for assistance in locating and correcting troubles which may occur. If a major repair or overhaul becomes necessary, the engine should be carefully checked and necessary repairs

made by a competent mechanic. Maintain factory limits and clearances as shown below, replacing worn parts when necessary.

## CLEARANCES

All clearances given at room temperature of 70°F.

	Minimum	Maximum
Tappet to Cylinder Block Clearance	0.0025"	0.004"
Valve Stem in Guide - Intake	0.001"	0.0035"
Valve Stem in Guide - Exhaust	0.0025"	0.004"
Valve Seat Interference Width	1/32"	3/64"
Valve <i>Face</i> Angle		44°
Valve <i>Seat</i> Angle		45°
Valve Interference Angle		1°
Crankshaft Main Bearing to Journal		
Steel-Backed Aluminum	0.0025"	0.0038"
Crankshaft End Play	0.006"	0.012"
Camshaft Bearing to Camshaft Clearance	0.0015"	0.0030"
Camshaft End Play	0.003"	
Rod Bearing to Crankshaft	0.002"	0.0033"
Connecting Rod End Play	0.002"	0.016"
Timing Gear Backlash	0.002"	0.003"
Piston to Cylinder (Measured under oil ring 90° from pin clearance)	0.0025"	0.0045"
Piston Pin in Piston	0.0001"	0.0005"
Piston Pin in Rod	0.0002"	0.0007"
Piston Ring Gap in Cylinder	0.013"	0.023"
Transistor Ignition Gap		0.008"
Spark Plug Gap		0.025"
Crankshaft Main Bearing Journal - Std. Size	1.9992"	2.0000"
Crankshaft Rod Bearing Journal - Std. Size	1.6252"	1.6260"
Cylinder Bore - Standard Size	3.5635"	3.5645"
Ignition Timing Advance - Fixed		
CAP. DISCH. Ignition (without Automatic Spark Advance)		20° BTC
Valve - Tappet Clearance		
Intake		.011"
Exhaust		.010"

## TORQUES

Assembly torques as given here require the use of a torque wrench. These assembly torques will assure proper tightness without danger of stripping the threads. If a torque wrench is not available, you will have to estimate the degree of tightness necessary for the stud, nut, or screw being installed and tighten accordingly. Be careful not to strip the threads. Check all studs, nuts and screws often. Tighten as needed to prevent them from working loose.

## Bolt Torque

	FT. - LB.
Rear Bearing Plate Cap Screws	30-35
Connecting Rod Bolt - Alum. Rod	24-26
Flywheel Cap Screw	40-45
Other 5/16" Cylinder block Studs and Nuts	10-12
Cylinder Head Capscrews	29-31
Gearcase Cover Screws	14-18
Oil Base Mounting Screws	38-43
Spark Plug	25-30
Starter Mtg. Brkt. to Block	25-30



# FUEL SYSTEM

## CARBURETOR

Carburetor maintenance should consist of regular cleaning. Some types of gasoline have a tendency toward formation of gum deposits inside the carburetor. This gum formation can usually be removed by soaking in alcohol or acetone. A fine, soft wire may be used to clean jets.

**Gasoline:** Adjusting the carburetor means obtaining the correct fuel-to-air mixture for smooth, efficient operation. The carburetor should be adjusted in two steps – first the idle adjustment and then the load adjustment (Fig. 5).

**Important:** If the carburetor is completely out-of-adjustment so the engine will not run, open both needle valves 1 to 1½ turns off their seats to permit starting. Do not

### CAUTION

Do not force the needle valves against their seats. This will bend the needle.

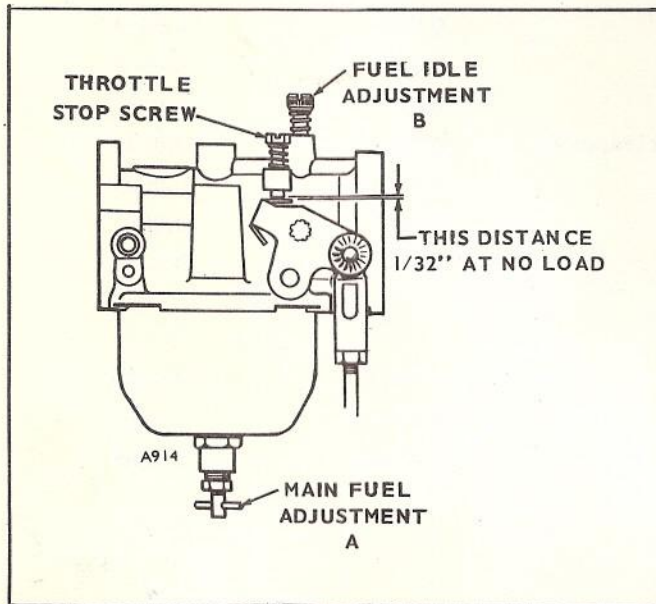

FIGURE 5. CARBURETOR

Before adjusting the carburetor, be sure the ignition system is working properly and the governor is adjusted. Then allow the engine to warm up.

1. With no load, turn the idle adjustment out until the engine speed drops slightly below normal. Then turn the needle in until speed returns to normal.
2. Apply a full load to the engine.
3. Carefully turn the main adjustment in until speed drops slightly below normal. Then turn the needle out until speed returns to normal.

*Alternate Method, Use When There is No-Load Adjustment Possible*

1. Start the engine and allow it to warm up.
2. Push in on the governor mechanism to slow the unit down to about 400-500 rpm.
3. Set the idle adjustment screw for even operation (so the engine is running smoothly).
4. Release the governor mechanism to allow the engine to accelerate. If the engine accelerates evenly and without a lag, the main adjustment is correct. If not, adjust the needle outward about ½ turn and again slow down the engine and release the mechanism. Continue until the engine accelerates evenly and without a time lag after releasing the governor.

With the carburetor and governor adjusted, set the throttle stop screw, Fig. 5 to allow 1/32" clearance to the stop pin with the engine operating at no load. This prevents excessive hunting when a large load is suddenly removed.

## Removal and Disassembly:

1. Remove the fuel line, governor linkage and air cleaner assembly.
2. Remove the two carburetor mounting nuts and pull off the carburetor.
3. Remove the air cleaner from the carburetor.
4. Remove the two screws that mount the choke to the carburetor and remove the assembly.
5. Remove the float bowl nut and bowl.
6. Remove the float pin and float Fig. 6.
7. Lift out the float valve and unscrew its seat.
8. Remove the no-load adjusting needle.
9. Remove the load adjusting needle and spring.
10. Remove the throttle plate screws and the plate and pull out the throttle shaft.
11. Remove the choke plate screws, plate, and pull out the choke shaft.

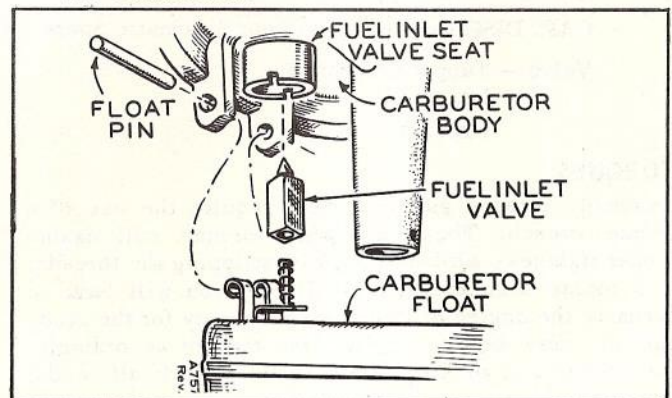

FIGURE 6. CARBURETOR DISASSEMBLY



**Cleaning and Repair:** To clean the carburetor, soak all components thoroughly in a good carburetor cleaner, following the cleaner manufacturer's instructions. Be sure all carbon is cleaned from the carburetor bore, especially in the area of the throttle valve. Blow out the passages with compressed air. If possible, avoid using wire to clean out the passages.

Check the adjusting needles and nozzle for damage. If float is loaded with fuel or damaged, replace it. The float should fit freely on its pin without binding. Invert the carburetor body and measure the float level, Fig. 7.

If necessary, bend the small lip that the intake valve rides on to adjust float level.

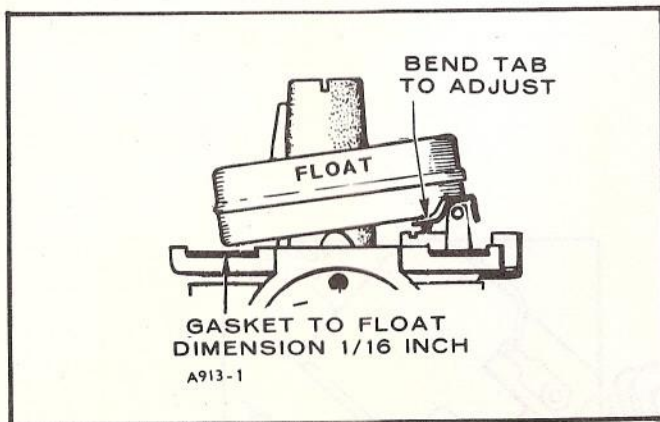

**FIGURE 7. ADJUSTING FLOAT LEVEL**

Check the choke and throttle shafts for excessive side play and replace if necessary. Do not remove the coating on the throttle shaft. This is teflon, used to reduce wear and friction between the shaft and carburetor body.

**Assembly and Installation:**

1. Install the throttle shaft and valve, using new screws and lock washers. Install with bevel mated to the carburetor body. To center the valve, back off the stop screw, close the throttle lever, and seat the valve by tapping it with a small screwdriver; then tighten the two screws.
2. Install choke shaft and valve. Center the valve in the same manner as the throttle valve (step 1). Use new screws and lock washers.
3. Install the main nozzle, making sure it seats in the body casting.
4. Install the intake valve seat and valve.
5. Install the float and float pin. Center the pin so the float bowl does not ride against it.
6. Check the float level with the carburetor casting inverted. See Fig. 7.
7. Install the bowl ring gasket, bowl and bowl nut. Make sure that the bowl is centered in the gasket, and tighten the nut securely.
8. Install the load adjusting needle with its spring. Turn in until it seats and back out 1 to 1½ turns.
9. Install the idle adjusting screw finger tight. Then back out 1 to 1½ turns.
10. Install the choke and adjust.
11. Install the carburetor on the engine and connect the gasoline inlet, governor mechanism, breather hose, and choke.
12. Install the air cleaner.

To check float level, remove the entire main fuel adjustment assembly from the float bowl (unscrew large nut from float bowl - Fig. 7). The proper level from the float to the gasket should be 1/16" with the valve spring compressed. The float tab should just touch the fuel inlet valve and not compress the inlet valve spring. Adjust by bending the tab on the float. *NOTE: Do not apply excessive pressure to float valve.*



## IGNITION AND BATTERY CHARGING ALTERNATOR

The engine is equipped with a flywheel mounted alternator which supplies voltage to both the ignition and battery charging circuits. The ignition system is a breakerless type. The battery charging circuit supplies approximately 10 amps maximum and 2 amps minimum battery charge rate.

## IGNITION

The breakerless ignition is factory-set and should normally require no adjustment. However, if through accident or misuse, the ignition system becomes out of adjustment, readjust as follows:

Examination of the outer rim of the flywheel will reveal a dowel pin protruding approximately  $3/16$ " from the surface. See Fig. 8. When this pin passes below the breaker module assembly, the spark is discharged to the spark plug, thus firing the fuel mixture in the combustion chamber. For proper ignition, the gap between the pin and the breaker module pin should be  $.008$ " when measured with a feeler gage. To adjust, loosen mounting bolts A and tap the assembly lightly, up or down as need be, until proper gap is attained. Tighten bolts A and recheck gap for accuracy. The timing advance is preset at the factory and cannot be changed.

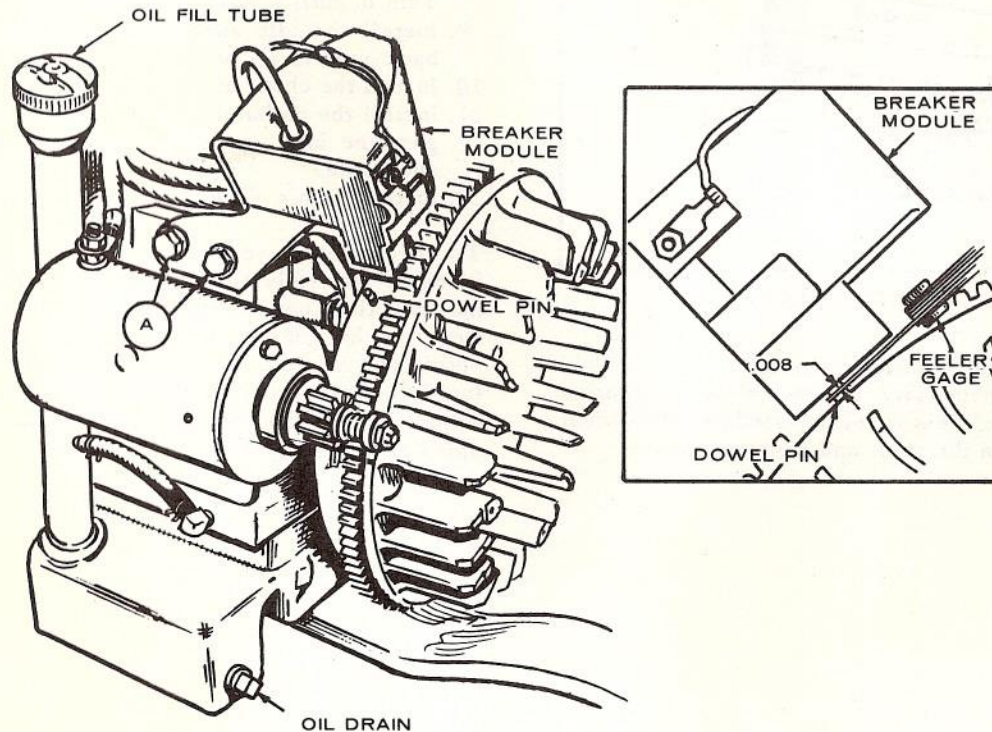

FIGURE 8. BREAKER GAP ADJUSTMENT



# VALVE SYSTEM

Properly seated valves are essential to good engine performance. The aluminum cylinder head is removable for valve servicing. Do not pry to loosen the cylinder head, rap sharply on the edge with a soft faced hammer, taking care not to break any cooling fins. A conventional type valve spring lifter may be used when removing the valve spring locks, which are of the split type. Clean all carbon deposits from the cylinder head, piston top, valves, guides, etc. If a valve face is burned or warped, or the stem worn, install a new valve.

Worn valve stem guides may be replaced from inside the valve chamber. Valve locks are split, tapered type, the smaller diameter of which must face toward the valve head. Tappets are also replaceable from the valve chamber, after first removing the valve assemblies.

The valve face angle is  $44^\circ$ . The valve seat angle is  $45^\circ$ . This  $1^\circ$  interference angle results in a sharp seating surface between the valve and the top of the valve seat. The interference angle method of grinding valves minimizes face deposits and lengthens valve life (Fig. 9).

The valves should not be hand lapped, if at all avoidable, since the sharp contact may be destroyed. Valve faces should be finished in a machine to  $44^\circ$ . Valve seats should be ground with a  $45^\circ$  stone, and the width of the seat band should be  $1/32$  to  $3/64$  of an inch wide. Grind only enough to assure proper seating.

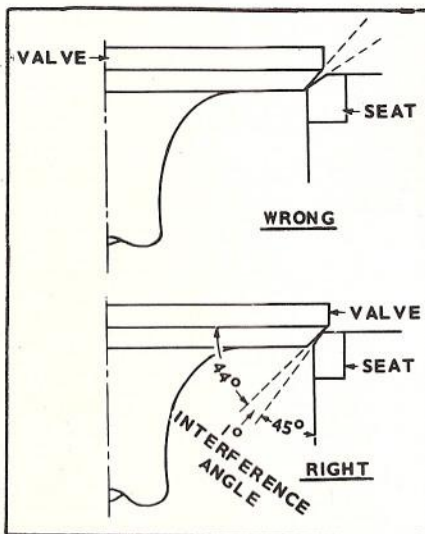

FIGURE 9. VALVE GRINDING

Remove all grinding compound from engine parts and place each valve in its proper location. Check each valve for a tight seat, using an air-pressure-type testing tool. If such a tool is not available, make pencil marks at intervals across the valve face and observe if the marks rub off uniformly when the valve is rotated part of a turn against the seat.

Lightly oil the valve stems and reassemble all parts removed. Adjust the valve clearance.

## TAPPET ADJUSTMENT

The engine is equipped with adjustable tappets. To make a tappet adjustment, remove the spark-plug and the valve cover. Turn the engine over by hand until the dowel pin in the flywheel is located within either of the shaded areas shown in Fig. 10. At this point the

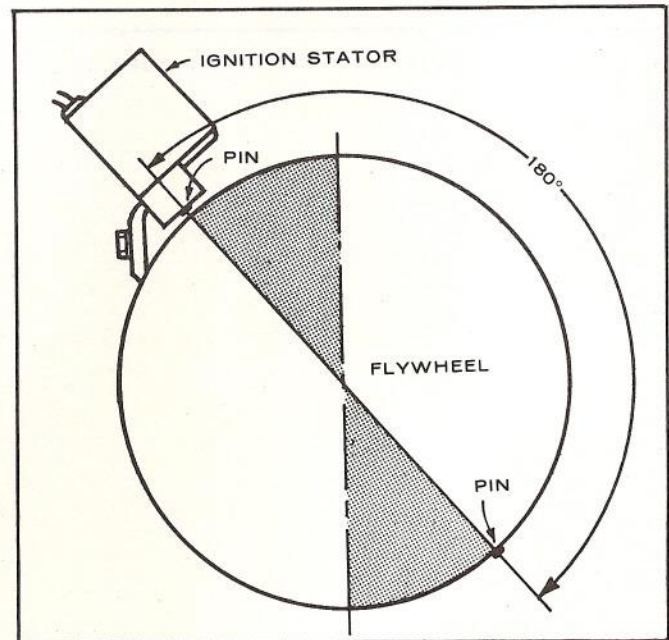

FIGURE 10. CLOSED VALVE POSITIONS

valve stems and the tappets should separate sufficiently to insert a feeler gauge (Fig. 11). Starting with the thickest gauge that will enter the gap, turn the adjusting screw and rock the flywheel gently until the clearances shown in the Table of Clearances are obtained.

For example, if the largest gauge that will enter is  $.014$ " on the exhaust valve, this means that the adjusting screw must be turned out. When at proper setting, the  $.011$ " feeler gauge will enter but the  $.012$ " gauge will not.



**NOTE:** Make sure to exert downward pressure on the tappet so that contact with the cam lobe is maintained when measurements are taken. If this is not done, a false measurement may result.

If more clearance is required, reverse the above procedure, but start with the smallest feeler gage and turn the adjusting screw in.

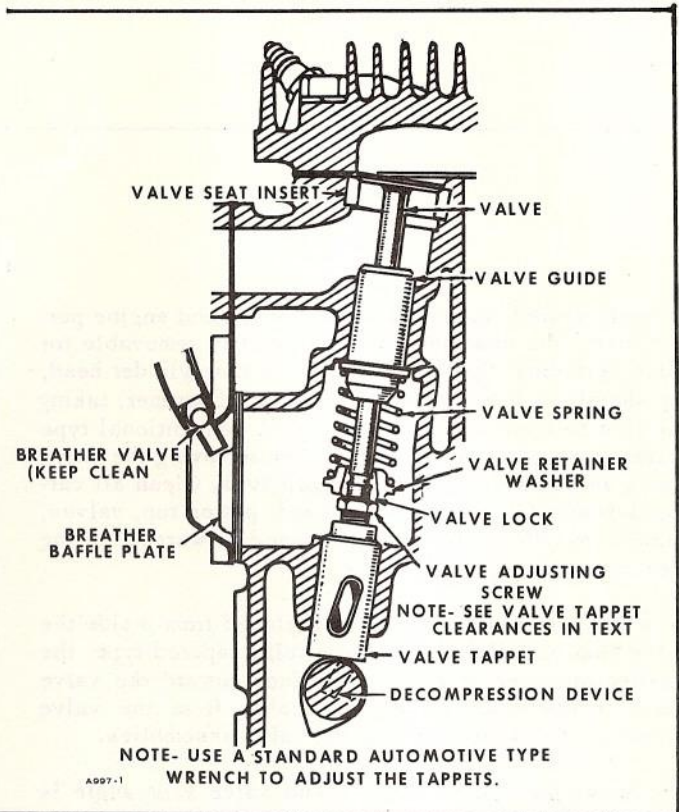
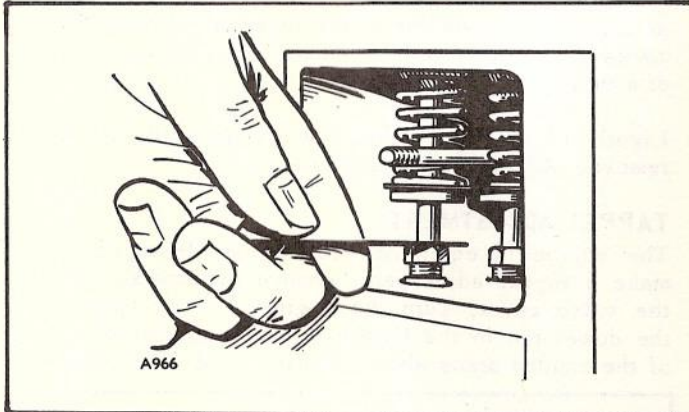

FIGURE II. TAPPET ADJUSTMENT

# ENGINE DISASSEMBLY

## GEAR COVER

After removing the mounting screws, tap the gear cover gently with a soft-faced hammer to loosen it.

When installing the gear cover, make sure that the pin in the gear cover engages the metal-lined (smooth) hole in the governor cup. Turn the governor cup so that the metal-lined hole is at the three o'clock position. The smooth side of the governor yoke must ride against the governor cup. Turn the governor arm and shaft clockwise as far as possible and hold in this position until the gear cover is installed flush against the crankcase. Be careful not to damage the gear cover oil seal. Adjust the roll (stop) pin to protrude to a point  $3/4$ " from the cover mounting surface.

## GOVERNOR CUP

With the gear cover removed, the governor cup can be taken off after removing the snap ring from the camshaft center pin. Catch the flyballs while sliding the cup off. See Fig. 12.

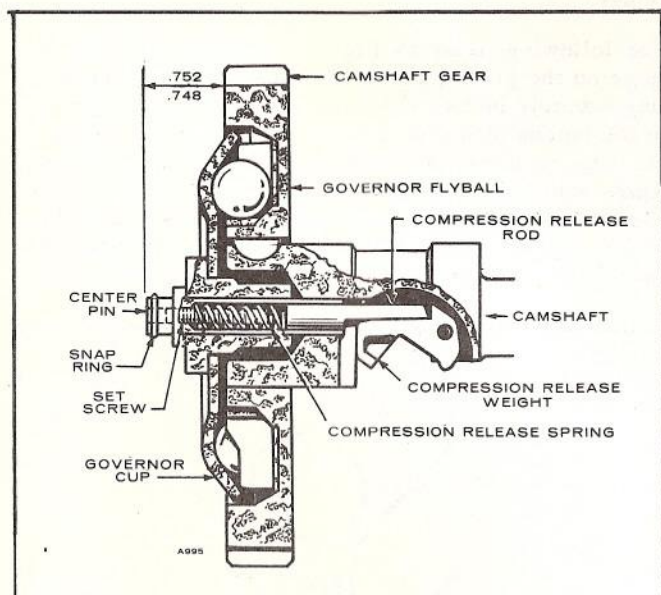

FIGURE 12. GOVERNOR CUP DETAILS

In order to facilitate easier cranking, a compression release has been built into the camshaft gear and governor assembly. See Fig. 12. This device holds the exhaust valve open approximately  $.020$ " on the compression stroke when starting. After the engine starts, the compression release weight retracts due to centrifugal force and the exhaust valve functions normally. No adjustment of this assembly is required nor possible.

Replace with a new part, any flyball which is grooved or has a flat spot, the ball spacer if its arms are worn or otherwise damaged, and the governor cup if the race surface is grooved or rough. The governor cup must be a free spinning fit on the camshaft center pin, but without excessive looseness or wobble.

When installing the governor cup, tilt the engine so the gear is up, put the flyballs in place (equally spaced), and install the cup and snap ring on the center pin. Fig. 12.

The camshaft center pin extends out  $3/4$ " from the end of the camshaft. This distance provides an in-and-out-travel distance of  $7/32$ " for the governor cup, as illustrated. Hold the cup against the flyballs when measuring. If the distance is less (the engine may race, especially at no load), remove the center pin and press a new pin in only the required amount. Otherwise, grind off the hub of the cup as required. The camshaft center pin cannot be pulled outward nor removed without damage. If the center pin extends out too far, the cup will not hold the flyballs properly.

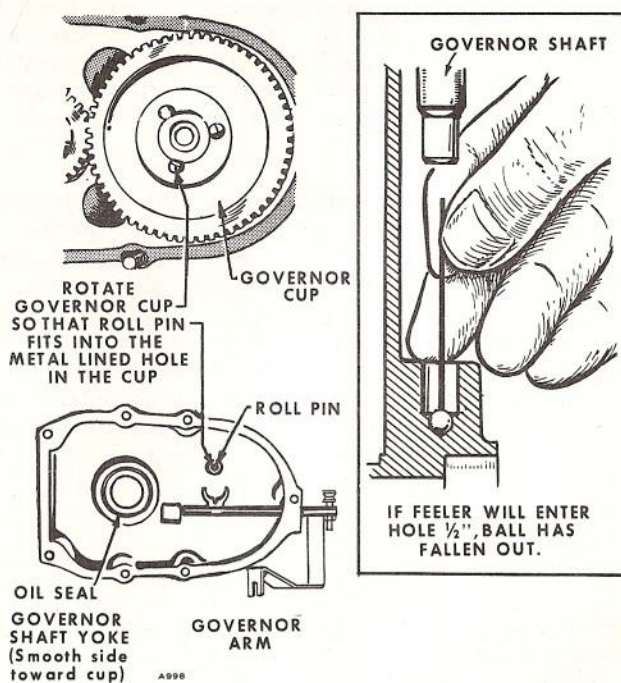

FIGURE 13. GEAR COVER ASSEMBLY





FIGURE 14. TIMING GEAR REMOVAL AND INSTALLATION

### TIMING GEARS

If replacement of either the crankshaft gear or the camshaft gear becomes necessary, install both gears new, never one only. To remove the crankshaft gear, first remove the snap ring, then insert two long #10-32 steel screws into the tapped gear holes and tighten the screws alternately. As the screws are tightened, the screw ends will seat against the crankshaft shoulder and force the gear off the end of the crankshaft. See Fig. 14.

The camshaft gear is pressed on and keyed to the camshaft. The camshaft and gear must be removed as an assembly, after first removing the crankshaft gear lock ring and washer. Before removing the camshaft and gear assembly, remove the cylinder head and valve assemblies. Remove the fuel pump and tappets. After removing the governor cup assembly from the gear, the camshaft may be pressed out of the gear by use of a hollow tool or pipe which will fit over the camshaft center pin. Do not press on the center pin or damage it in any way. The governor ball spacer is a press fit to the camshaft gear.

When pressing a camshaft gear onto the camshaft, be sure the gear is started straight and that the key is properly in place. Install the governor cup assembly before installing the camshaft and gear in the engine.

Each timing gear is stamped with O mark near the edge. The gear teeth must mesh so that these marks exactly coincide when the gears are installed in the engine. Be sure, when installing the camshaft gear and shaft assembly, that the thrust washer is properly in place behind the camshaft gear. Replace the retaining washer and lock ring to the crankshaft.

### PISTONS AND RINGS

The piston and connecting rod assembly is removed outward from the cylinder. The pistons are fitted with two compression rings and one oil control ring with an expander. Inspect each piston. The piston ring grooves should be cleaned of any carbon deposits, and the oil return slots in the lower groove must be open.

If the pistons are badly scored, very loose in the cylinder, have badly-worn ring grooves, or otherwise are not in good condition, install new pistons. Install new pistons if the old ones are loose on the piston pins and 0.002" oversize piston pins will not correct it. Handle pistons carefully to avoid nicking the walls. Any raised surface of this type must be dressed down carefully.

Inspect the rings carefully for fit in grooves, for tension, and for seating on cylinder walls. Install new rings where there is any doubt about the condition of the old rings.

For following, refer to Fig. 15. Before installing new rings on the piston, check the ring gap by placing each ring squarely in its cylinder at a position corresponding to the bottom of its travel. The gap between the ends of the ring is given in Clearances (see Repair Section). Rings which are slightly oversize may be filed as necessary to obtain the correct gap, but do not use rings which require too much filing. Standard size rings may be used on .005" oversize pistons. .010", .020", .030"

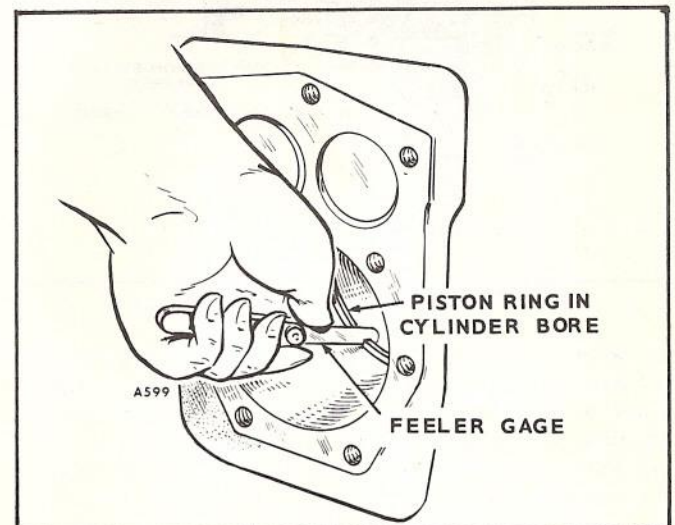

FIGURE 15. FITTING PISTON RINGS TO TYPICAL CYLINDER



and .040" oversize rings are to be used on corresponding oversize pistons. Rings of the tapered type are usually marked *top* on one side, or identified in some other manner, and the ring must be installed with this mark toward the closed end of the piston.

Space each ring gap one third of the way around the piston from the preceding one, with no gap directly in line with the piston pin. The bottom piston ring groove should be fitted with an expander and an oil control ring and the two upper grooves fitted with compression rings. The chrome-faced ring should be fitted in the top groove. The oil control ring is selected for best performance in regard to the correct unit pressure characteristics.

The piston is fitted with a full-floating-type piston pin. The pin is kept in place by two lock rings in the piston, one at each side. Be sure these lock rings are properly in place before installing the piston and connecting rod in the engine. Refer to Table of Torques and Clearances for the correct piston-to-cylinder clearance.

### CONNECTING RODS

The connecting rods should be serviced at the same time the pistons or piston rings are serviced. Rods must be removed with the piston. Rods are available in standard or .010", .020" or .030" undersize.

Install the connecting rods and caps as shown in Fig. 16. Coat the crankshaft journal bearing surfaces with oil before installing the rods. Crank the engine by hand to see that the rods are free. If necessary, rap the connecting rod cap screws sharply with a soft faced hammer to set the rod square on the journal.

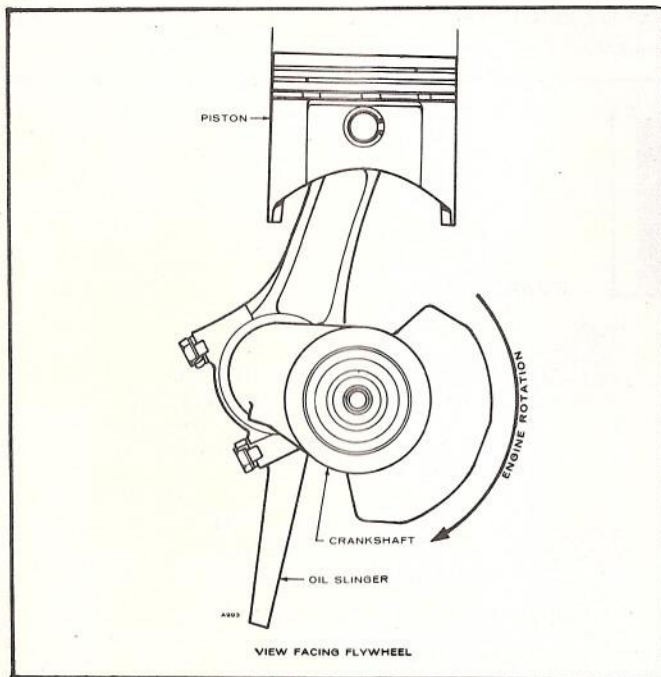

FIGURE 16. CONNECTING ROD INSTALLATION

### CRANKSHAFT

Inspect the bearing journals. If they are scored and cannot be smoothed out by dressing down, the bearing journals should be refinished to use nearest available undersize bearings or a new crankshaft should be installed. If a worn main bearing journal cannot be fitted with an available precision type undersize bearing, then refinish it to the next undersize.

### BEARINGS

Removal of the camshaft or crankshaft bearings requires complete disassembly of the engine. Use a press or a suitable drive plug to remove the bearings. Support the casting to avoid distortion and avoid damaging the bearing bore during removal and installation. Use oil on the bearings to reduce friction when installing and again lubricate with oil after installing. See Fig. 18.

New crankshaft main bearings are precision type which *do not* require line reaming or line boring after installation. They are available in standard size, .002", .010", .020" or .030" undersize. Expand the bearing bore by placing the casting in hot water or in an oven heated to 200°F. Warning: *If a torch is used, apply only a little heat.* If practical, cool the precision bearing to shrink it. Align the oil hole(s) in the bearing with the oil hole(s) in the bearing bore. The oil passage must be at least 1/2 open. The cold oiled precision bearing should require only light taps to position it. Install the bearing flush with the inside end of the bore. If head of lock pin is damaged, use side cutters or Easy Out tool to remove and install new pin. Apply oil to thrust washer to hold it in place while installing the crankshaft. Oil grooves in thrust washers must face the crankshaft, washers must be flat (not bent) and washers two notches must fit over two lock pins to prevent riding on crankshaft.

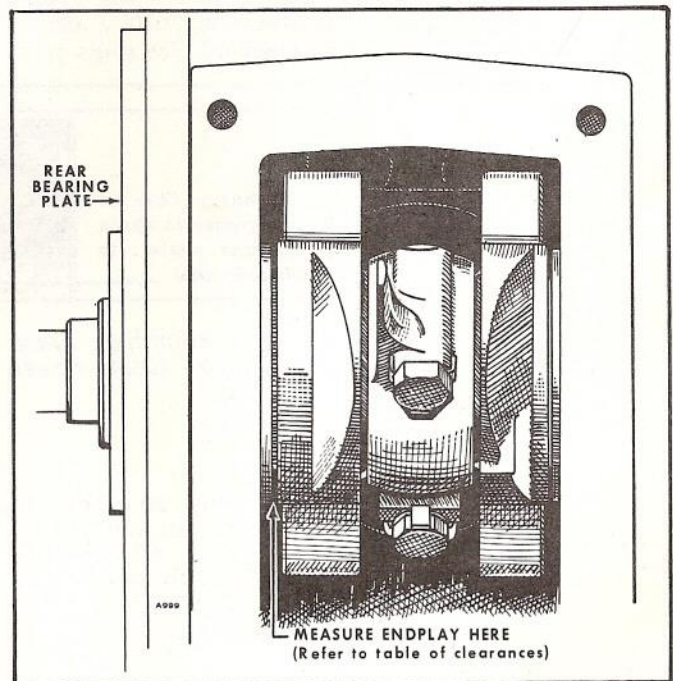

FIGURE 17. CRANKSHAFT ENDPLAY



New camshaft bearings are precision type which *do not* require line reaming or line boring after installation. Coat the bearing with lubricating oil to reduce friction. Place the bearing on the crankcase over the bearing bore with the elongated hole in proper position and narrow section facing out (except bores without oil holes install with bearing groove at the top). Be sure to start the bearing straight. Press the front bearing in flush with the outside end of the bearing bore. Press the rear bearing in flush with the bottom of counterbore which receives the expansion plug.

### OIL SEALS

The bearing plate must be removed to replace its oil seal. Drive the oil seal out from the inside.

Before installing the seals, fill the space between seals with a fibrous grease or stiff cup grease. This will improve sealing. See Fig. 19.

When installing the gear cover oil seal, tap the seal inward until it is  $\frac{31}{32}$  of an inch from the mounting face of the cover. Install new style, thin, open-face seal  $1\frac{7}{64}$ " from the mounting face of cover.

When installing the bearing plate oil seal, tap the seal into the bearing plate bore to bottom against the shoulder in the plate bore. Use a seal expander, or place a piece of shim stock around the end of the crankshaft, when replacing the bearing plate to avoid damaging the seal. Remove the shim stock as soon as the plate is in place.

### CYLINDER

The cylinder wears very little in normal service. If, through improper lubrication or accident, the cylinder wall should become scored or worn badly, the cylinder may be rebored and honed to accommodate a new piston and ring set of the available oversizes. Pistons are available in .005", .010", .020", .030" and .040" oversize. Piston rings are available in .010", .020", .030" and .040" oversize. Use standard size rings on a

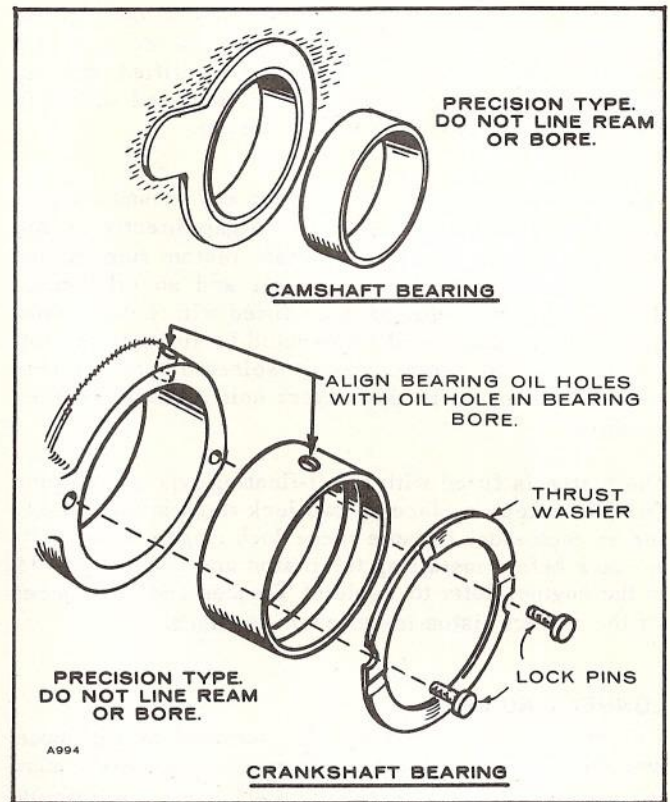

FIGURE 18. CAMSHAFT AND CRANKSHAFT BEARINGS

.005" oversize piston. If the cylinder is not being reconditioned, but new piston rings are being installed, remove any ridge which may have become formed at the top of piston ring travel in the cylinder bore. Engine might be fitted at the factory with a .005" oversize piston and are so indicated by a letter E following the engine serial number stamped on the cylinder block and on the unit nameplate. The standard cylinder bore size appears in Table of Torques and Clearances.

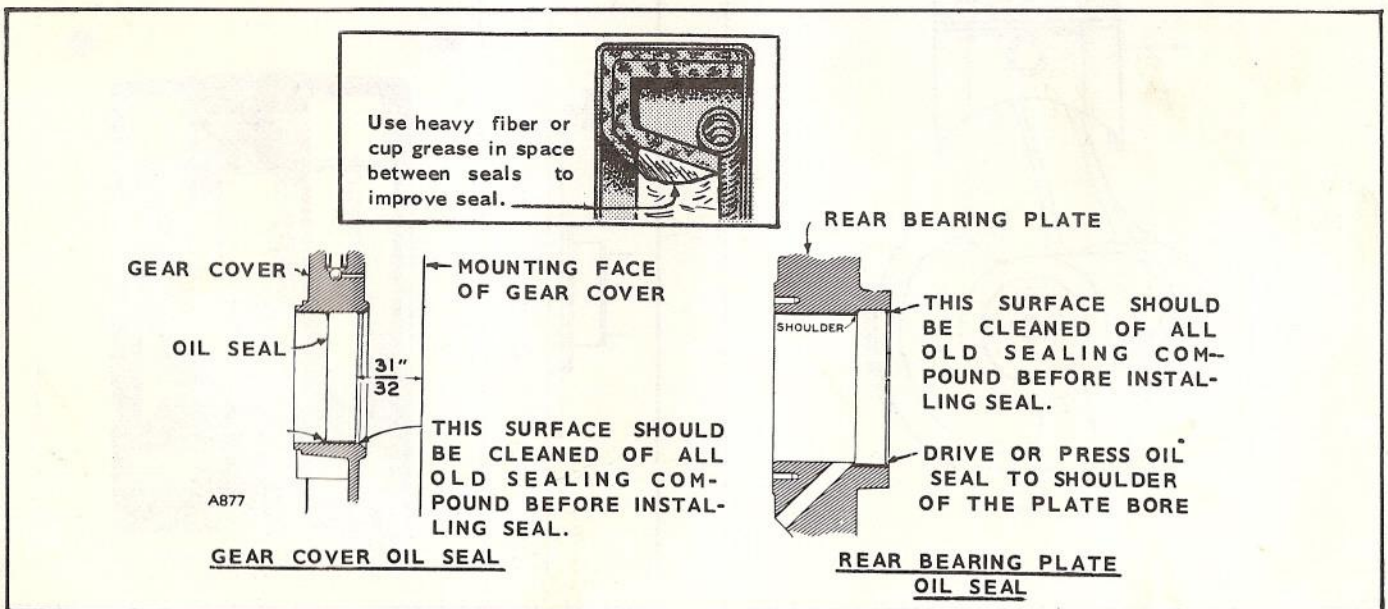

FIGURE 19. GEAR COVER AND REAR BEARING PLATE OIL SEALS

## CYLINDER HEAD

The cylinder head bolts should be tightened in the order designated and to the torque specified at the time the engine is assembled or the cylinder head replaced. This should be at room temperature. At some later time, after the engine has been operated so it reached normal hot temperature *and allowed to cool to room temperature*, the cylinder head bolts should be re-torqued to the original specified torque. This re-tightening should be done before the engine has been run a total of fifty operating hours.

## FLYWHEEL

To remove the flywheel, turn the flywheel mounting screw outward about two turns. Use a screwdriver behind the flywheel to take up the crankshaft end play. Then strike a sharp endwise blow on the head of the cap screw with a heavy soft-faced hammer to loosen. A suitable puller (with claws or with bolts to agree with flywheel) may be used to pull the flywheel.

Do not drop the flywheel. A broken fin will destroy the balance. Always use a steel key for mounting the flywheel.

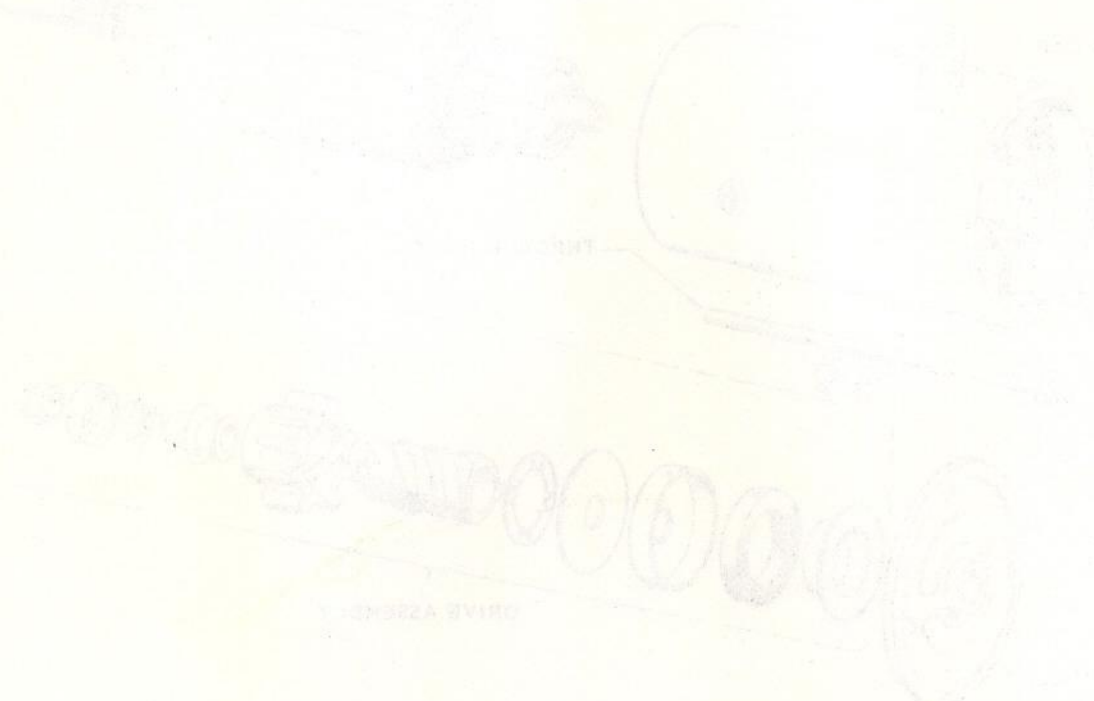



# STARTING SYSTEM

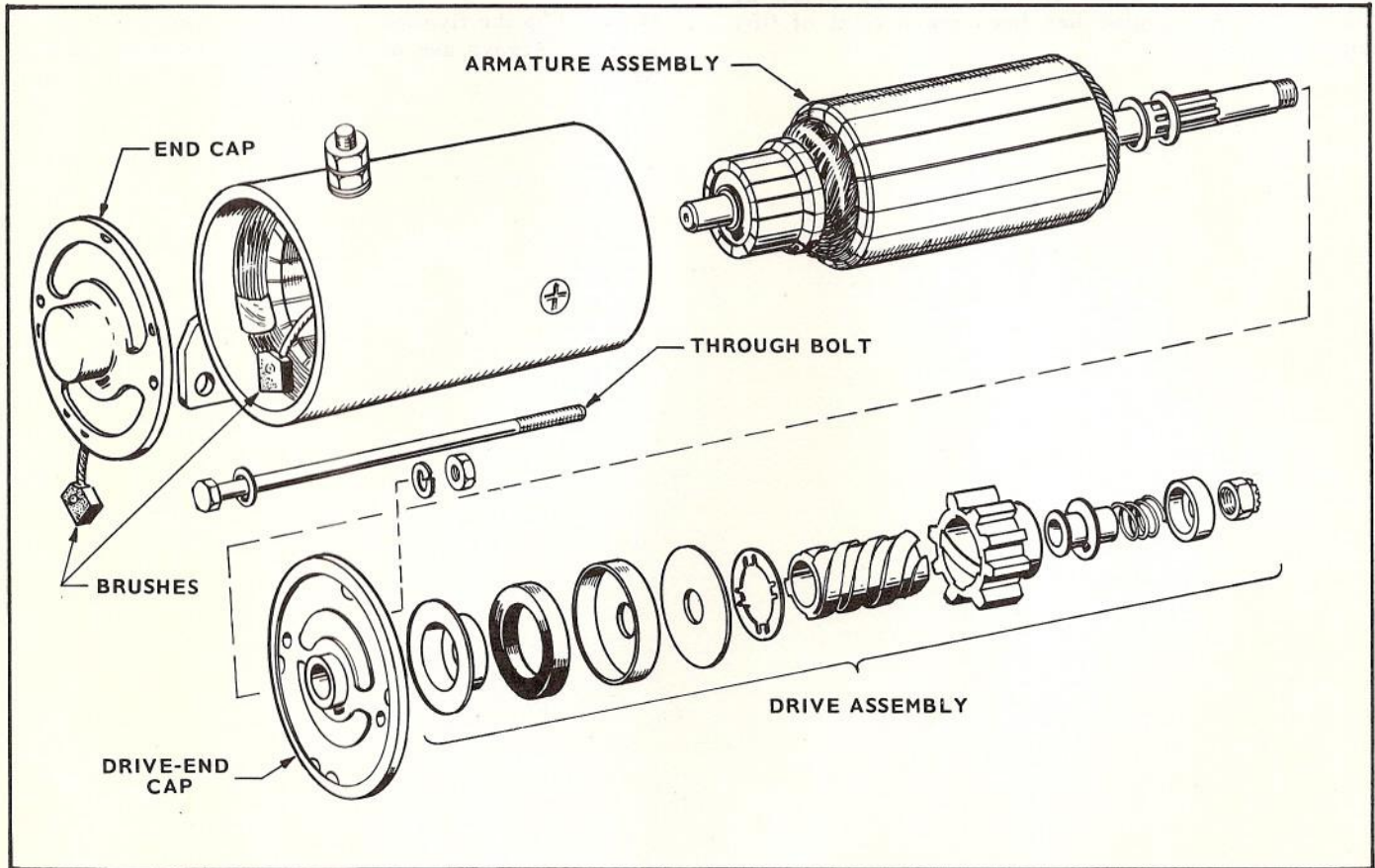

FIGURE 27. ELECTRIC STARTER ASSEMBLY

## ELECTRIC STARTER

Over a period of time, depending upon operating conditions, the electric starter may require minor maintenance such as brush replacement. Complete overhaul may be needed if the starter has been damaged through misuse or accident. The following instructions detail disassembly, reassembly, repair, testing, and maintenance.

## DISASSEMBLY

Figure 27 is the exploded view of the cranking motor. The disassembly is performed in the following sequence.

1. Remove the through-bolts.
2. The armature, drive and cap assembly and drive assembly are removed as a unit from the drive end. The end cap assembly may be taken off by removing the brushes from the brush holders.
3. If necessary, the drive assembly may be disassembled further by removing the self-locking nut.
4. Remove the terminal, if required.

## CLEANING

1. Such parts as the field coil, armature, and brushes are wiped with a clean dry cloth. If compressed air is available this may be used.
2. Bearing equipped parts should not be soaked in a non-petroleum base solvent. These parts are soaked in mineral spirits and cleaned by brushing.
3. The rubber cushion should be cleaned in non-flammable solvent, but never in mineral spirits.
4. All parts that have been washed in solvent should be well dried before use.

## REASSEMBLY

Reassembly is the reverse of disassembly. The following precautions should be taken.

1. Apply a film of medium engine oil to the bearing portions before reassembly. Also to the exterior and interior of the shaft screw a small quantity of a very light grade oil should be applied; medium or



heavy oil and grease may cause to the drive assembly to stick in cold weather.

2. Spline threads are provided up to the mid portion of the interior of screw sleeve and when assembling the drive assembly the spline thread portion should be on the armature aide.
3. After the drive assembly is assembled on the shaft the self locking nut is tightened by a torque of 170-220 in-lbs.
4. The armature should be adjusted by spacing washers to give end play of .005" - .015".
5. The thru-bolts are tightened by a torque of 35 - 44 in-lbs.

### PERFORMANCE TEST

1. No load test:

The cranking motor is wired up as shown in Figure 28 and run. The values of meter readings should be as follows:

Battery Voltage	11.8 V
Minimum RPM	8,000
Maximum Current Draw	25 Amperes

If the above meter readings are obtained, operation is considered satisfactory.

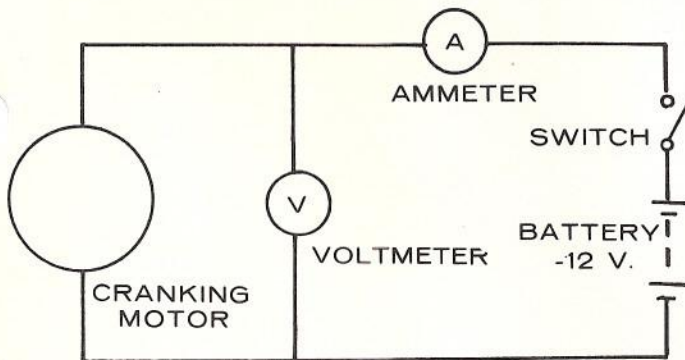

FIGURE 28. CRANKING MOTOR WINDINGS

**NOTE:** The conductor for the testing should be at least #14AWG and as short as possible for no-load testing.

2. Inspection of Drive Assembly:

The operation of the drive assembly is inspected by instantaneously applying rated voltage to the connection circuit in Figure 28.

3. If in either 1 or 2 above an abnormal condition is found, the following inspections are to be made:

- Annealed brush springs
- Improperly seated brushes
- Insufficient armature end play
- Shorted or open armature
- Shorted or grounded armature

- Shorted or grounded field
- Poor electrical connection
- Dirty commutator

### INSPECTION

1. Inspection for Grounded Armature:

Grounds in the armature can be detected by the use of a test lamp and test points. If the lamp lights when one test point is placed on the commutator with other point on the core or shaft, the armature is grounded.

2. Inspection for Shorted Armature:

Short circuits in the armature are located by use of a growler. When the armature is revolved in the growler with a steel strip such as a hack-saw blade held above it, the blade will vibrate above the area of the armature core in which the short circuit is located.

3. Inspection for Open in the Armature:

The most likely place for an open to occur is at the commutator riser bars. Inspect the points where the conductors are joined to the commutator bars for loose connections.

4. Inspection for Open in the Field Coil:

Connect test lamp leads to ends of field coils. If lamp does not light, the field coils are open.

5. Inspection for Grounded Field Coil:

Connect one lead of the test lamp to the yoke and the other lead to the field connector. If the lamp lights, field coil is grounded.

6. Brush Inspection:

When brushes are worn more than 3/8 in. they are to be replaced. Figure 29 shows the limit for wear. See that the brushes move smoothly in the brush holder.

7. Inspection for Brush Spring Pressure:

If the pressure on the tension testing measures 17-25 ounces the pressure on the brush will be sufficient.

8. Drive Assembly Inspection:

Fully compress the drive spring and make certain that the gear assembly freely returns to its original position.

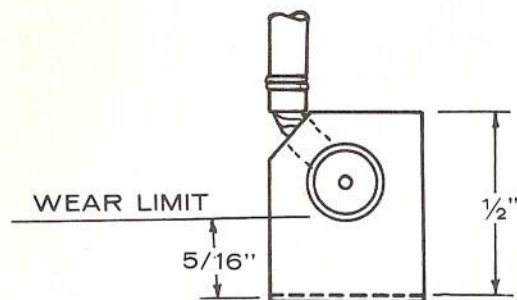

FIGURE 29. BRUSH INSPECTION FOR WEAR



**Precautions To Be Taken After Service:**

1. The shaft of the cranking motor and the central axis of the engine must be parallel and the mounting bolts should be tightened so that cranking motor does not shift when starting. When tightening is incomplete or any foreign material exists at the mating surface, damage such as cracking the housing may occur.
2. When cranking motor is used the following cranking time should be observed.
  - a. Do not put the cranking motor in continuous operation for more than 20 seconds.
  - b. Between 20 seconds of cranking time give 30 seconds of rest time between each cranking cycle.
  - c. Do not repeat the above (a) step more than 5 times. If the engine does not start, there may be some other cause for non-start and this must be inspected.
3. If the engine does not crank do not leave the starter in a stall (locked rotor) condition longer than 10 seconds.
4. This cranking motor requires no oiling but when it is dismantled, lubrication should be done as instructed in Disassembly Section.
5. When brush length becomes shorter than 3/16" it is no longer suited for use (see Figure 29). Always replace with genuine Onan parts.



# PARTS CATALOG

This parts catalog applies to Onan Engines, NB-MS/1846A and NB-MS/1847A.

Parts are arranged in groups of related items. Each illustrated part is identified by a reference number corresponding to the same reference number in the Parts List for the group.

Common hardware items such as screws, washers, nuts, etc., which are available locally are not listed.

## INSTRUCTIONS FOR ORDERING REPAIR PARTS

For parts or service, contact the dealer from whom you purchased this equipment or refer to your Nearest Authorized Parts & Service Center.

To avoid errors or delay in filling your parts order, please furnish all information requested.

Always refer to the nameplate on your plant:

1. Always give the MODEL & SPEC. NO. and SERIAL NO.

	
MODEL AND SPEC NO.	
[REDACTED]	
SERIAL NO.	
[REDACTED]	
<b>IMPORTANT</b> - ALWAYS GIVE ABOVE NOS WHEN ORDERING PARTS	
HORSEPOWER [REDACTED]	
OIL CAPACITY ..... 2 QUARTS	
CHECK OIL LEVEL DAILY	
BELOW 30°F - SAE 5W20	
ABOVE 30°F - SAE 30	
CHANGE OIL AFTER FIRST 5 HOURS.	
CHANGE OIL EVERY 40 OPERATING HOURS.	
EVERY 20 HOURS ... DUSTY CONDITIONS.	
FUEL ..... REGULAR GASOLINE	
BATTERY ..... 12V NEG GND	
DO NOT REVERSE BATTERY CONNECTIONS.	
VALVES (COLD) ..... IN-.011 EXH-.010	
SPARK PLUG GAP ..... .025	
TRANSISTOR IGN GAP ..... .008	
MANUFACTURED BY	
<b>ONAN</b>	
DIV. OF STUDEBAKER CORPORATION	
MINNEAPOLIS, MINNESOTA, U.S.A.	
99A1143	

2. Do not order by reference number or group number, always use part number and description.
3. Give the part number, description and quantity needed of each item. If an older part cannot be identified, return the part prepaid to your dealer or nearest AUTHORIZED SERVICE STATION. Print your name and address plainly on the package. Write a letter to the same address stating the reason for returning the part.
4. State definite shipping instructions. Any claim for loss or damage to your unit in transit should be filed promptly against the transportation company making the delivery. Shipments are complete unless the packing list indicates items are back ordered.

Prices are purposely omitted from this Parts Catalog due to the confusion resulting from fluctuating costs, import duties, sales taxes, exchange rates, etc.

For current parts prices consult your Onan Dealer, Distributor, or Parts and Service Center.



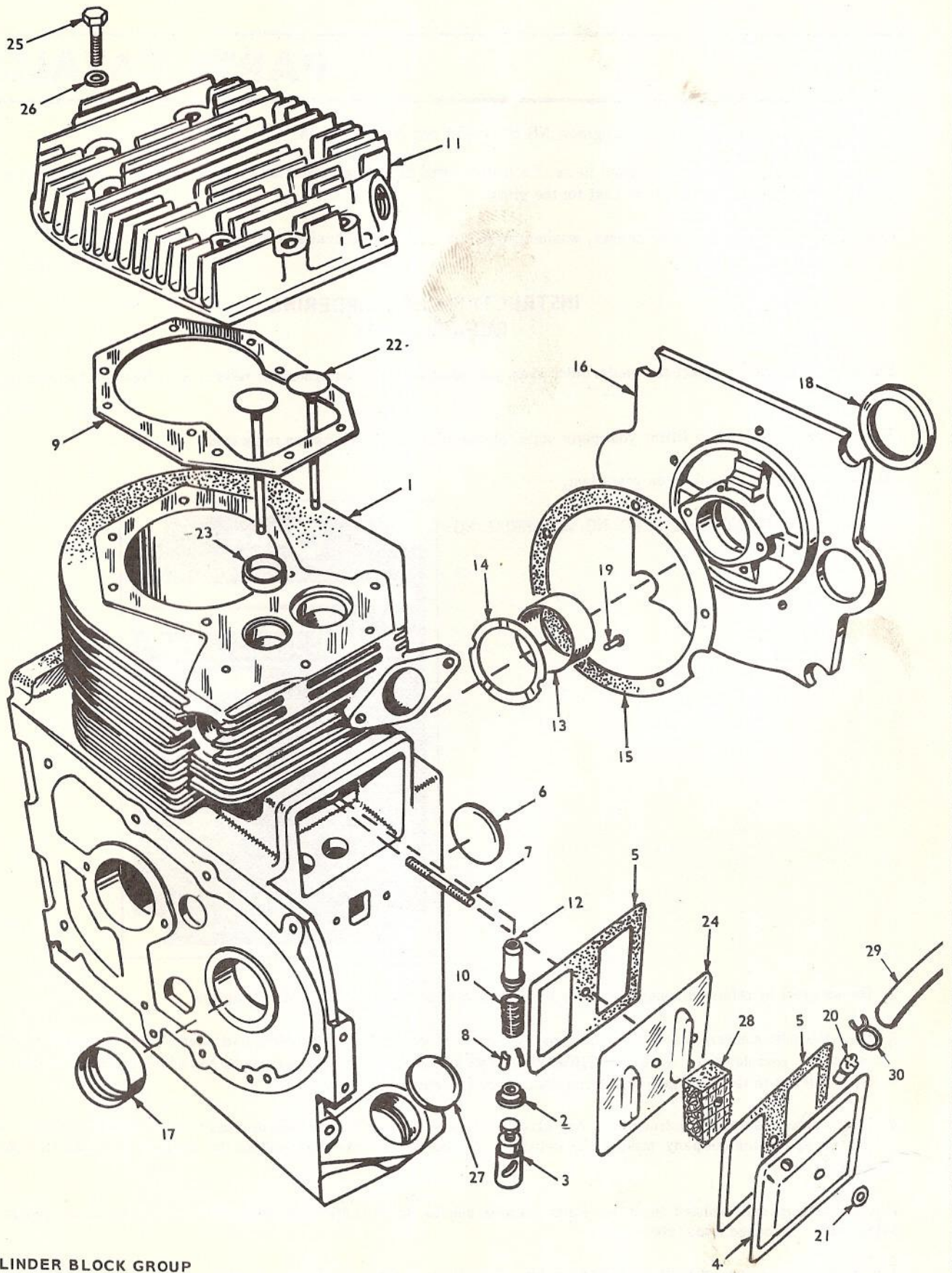

CYLINDER BLOCK GROUP



REF. NO.	PART NO.	QTY. USED	PART DESCRIPTION
1	110A1814	1	Block Assembly, Cylinder - Includes Parts Marked *
2	110A893	2	Washer, Retainer - Valve
3	TAPPET, VALVE		
	115A6	2	Standard
	115A6-05	2	.005" Oversize
4	110A1782	1	Cover, Valve Compartment
5	110A1791	2	Gasket, (1) Valve Cover, (1) Baffle
6	517-48	1	*Plug, Expansion - Camshaft
7	520A634	1	Stud, Valve Compartment Cover
8	110A639	4	Lock, Valve
9	110B1731	1	Gasket, Cylinder Head
10	110A539	2	Spring, Valve
11	110D1733	1	Head, Cylinder
12	*GUIDE, VALVE		
	110A1759	1	Intake
	110A1760	1	Exhaust
13	BEARING, CRANKSHAFT		
	101K389	2	*Standard
	101K389-02	2	.002" Undersize
	101K389-10	2	.010" Undersize
	101K389-20	2	.020" Undersize
	101K389-30	2	.030" Undersize
14	104A575	2	*Washer, Crankshaft Bearing Thrust
15	101K397	1	*Gasket Kit, Bearing Plate
16	101C414	1	*Plate, Rear Bearing (Excludes Brg.)
17	101A367	2	*Bearing, Camshaft (Precision)
18	509A41	1	*Seal, Bearing Plate

REF. NO.	PART NO.	QTY. USED	PART DESCRIPTIONS
19	516A72	4	*Pin, Main Bearing Stop
20	123A486	1	Valve, Breather
21	526-63	1	Washer, Valve Compartment Cover (Copper)
22	VALVE		
	110B1718	1	Intake
	110B1761	1	Exhaust (Stellite)
23	INSERT, EXHAUST VALVE SEAT (STELLITE)		
	110A1785	1	Standard
	110A1785-02	1	.002" Oversize
	110A1785-05	1	.005" Oversize
	110A1785-10	1	.010" Oversize
	110A1785-25	1	.025" Oversize
24	110A1783	1	Baffle, Breather Plate
25	SCREW, HEX HEAD CAP		
	102A455	4	Cylinder Head (3/8-16 x 1-1/4") (Special)
	800-515	4	Cylinder Head (3/8-16 x 1-3/4") (Special)
	800-516	2	Cylinder Head (3/8-16 x 2") (Special)
	800-517	5	Bearing Plate (5/16-18 x 7/8") (Special)
26	526A174	10	Washer, Flat - Cylinder Head
27	517-97	1	*Plug, Oil Fill Hole
28	123A996	1	Element, Breather
29	503A574	1	Hose, Breather
30	503-170	1	Clamp, Breather Hose

### GEAR COVER AND OIL BASE GROUP

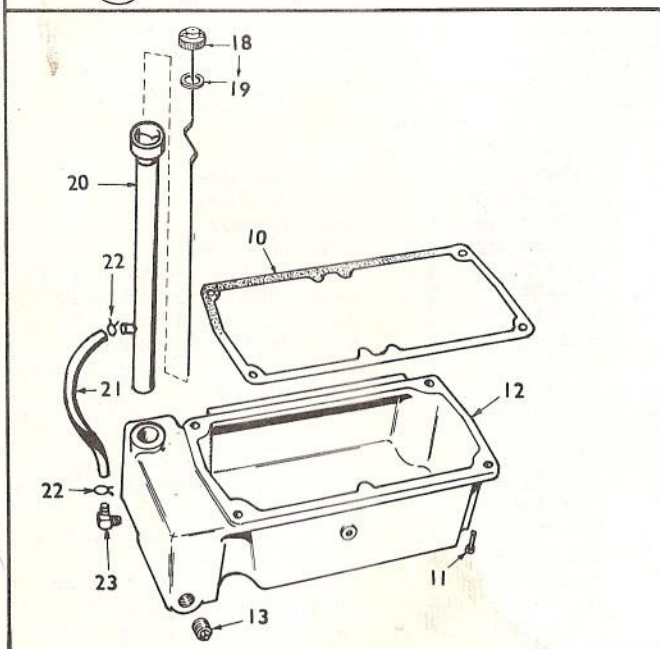
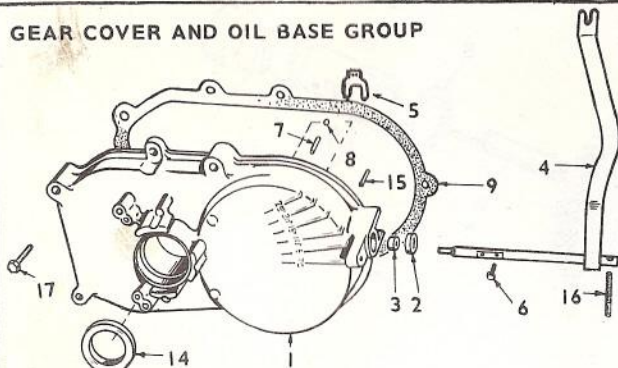

REF. NO.	PART NO.	QTY. USED	PART DESCRIPTION
1	103B353	1	Cover Assembly, Gear - Includes Parts Marked *
2	509P8	1	*Seal, Oil - Governor Shaft
3	510P13	1	*Bearing, Gov. Shaft (Upper)
4	150B1043	1	*Shaft & Arm, Governor
5	150A1187	1	*Yoke, Governor Shaft
6	822-46	2	*Screw, Gov. Yoke Mtg. (Spec.)
7	516-130	1	*Pin, Governor Cup Stop (In Gear Cover)
8	510P14	1	*Ball, Bearing - Gov. Shaft
9	103B11	1	Gasket, Gear Cover
10	102B107	1	Gasket, Oil Base Mtg.
11	800-51	4	Screw, Cap - Oil Base to Block
12	102D634	1	Base, Oil
13	505-110	1	Plug, Oil Drain
14	509A40	1	*Seal, Gear Cover
15	516-11	2	Pin, Gear Cover (5/16 x 3/4")
16	150A96	1	*Stud, Governor Sensitivity
17	SCREW, HEX HEAD CAP - GEAR COVER		
	114-22	4	5/16-18 x 1-3/4"
	800-34	1	5/16-18 x 2-1/4"
18	123A1106	1	Cap and Indicator, Oil Fill
19	123A191	1	Gasket, Oil Fill Cap
20	123B1115	1	Tube, Oil Fill
21	503B589	1	Line, Oil Balance
22	503P301	2	Clamp, Oil Balance Line
23	502-313	1	Elbow, Oil Balance Line



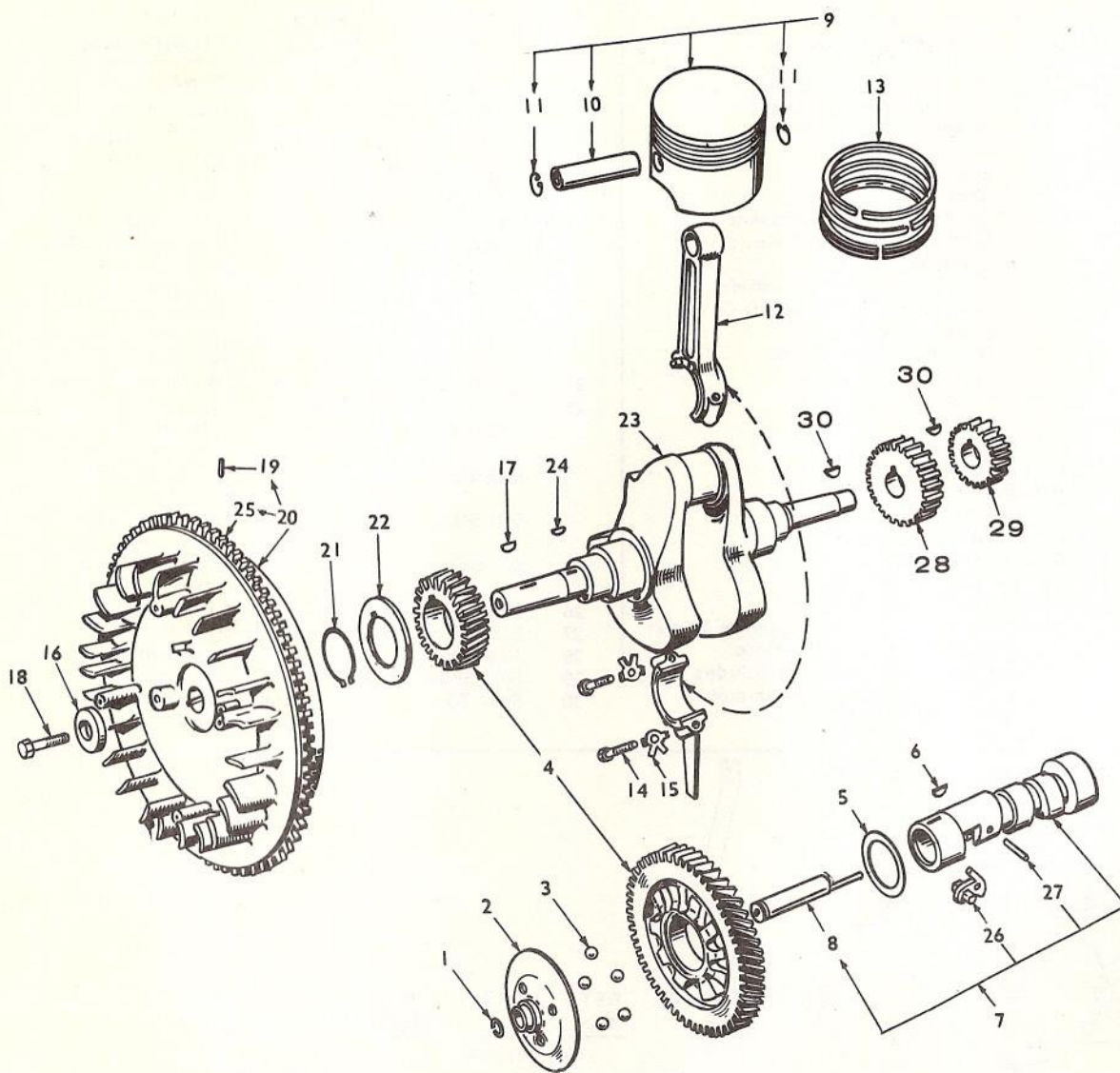

CRANKSHAFT, FLYWHEEL, CAMSHAFT AND PISTON GROUP

REF. NO.	PART NO.	QTY. USED	PART DESCRIPTION	REF. NO.	PART NO.	QTY. USED	PART DESCRIPTION
1	150A78	1	Ring, Camshaft Center Pin	13	RING SET, PISTON		
2	150B1116	1	Cup, Governor	113A142		1	Standard
3	510-15	5	Ball, Fly- Governor	113A142-10		1	.010" Oversize
4	105A353	1	Gear Set, Timing - Includes Camshaft & Crankshaft Gear (Incl. Flyball Spacer & Plate)	113A142-20		1	.020" Oversize
5	105A4	1	Washer, Camshaft Gear Thrust	113A142-30		1	.030" Oversize
6	515-1	1	Key, Camshaft Gear Mounting	113A142-40		1	.040" Oversize
7	105C338	1	Camshaft - Includes Center Pin Assy. & Compression Relief	14	114A171	2	Screw, Connecting Rod Cap (Spec.)
8	150A1296	1	Pin Assy., Center - Governor	15	114A59	2	Lock, Connecting Rod Screw
9	PISTON & PIN (INCLUDES RETAINING RINGS)			16	526A17	1	Washer, Flywheel Mounting
	112A111	1	Standard	17	515-2	1	Key, Flywheel Mounting
	112A111-10	1	.010" Oversize	18	104A170	1	Screw, Flywheel Mounting (Special)
	112A111-20	1	.020" Oversize	19	516P183	1	Pin, Flywheel
	112A111-30	1	.030" Oversize	20	134B2104	1	Flywheel - Includes Ring Gear & Pin
	112A111-40	1	.040" Oversize	21	518-14	1	Lock, Crankshaft Gear Washer
10	PIN, PISTON			22	104A43	1	Washer, Crankshaft Gear Retainer
	112A112	1	Standard	23	104D720	1	Crankshaft
	112A112-02	1	.002" Oversize	24	515-1	1	Key, Crankshaft Gear Mounting
11	518P294	2	Ring, Piston Pin Retaining	25	104C721	1	Gear Ring
12	ROD, CONNECTING- INCLUDES LOCKS & SCREWS			26	105D289	1	Weight, Compression Release
	114D204	1	Standard	27	516-181	1	Pin, Compression Release
	114D204-10	1	.010" Oversize	28	190A284	1	Gear, Trans. Drive (3-3/16")
	114D204-20	1	.020" Oversize	29	180A285	1	Gear, Trans. Drive (2-5/16")
	114D204-30	1	.030" Oversize	30	515-94	2	Key, Transmission Drive Gears





### FUEL PUMP PARTS GROUP

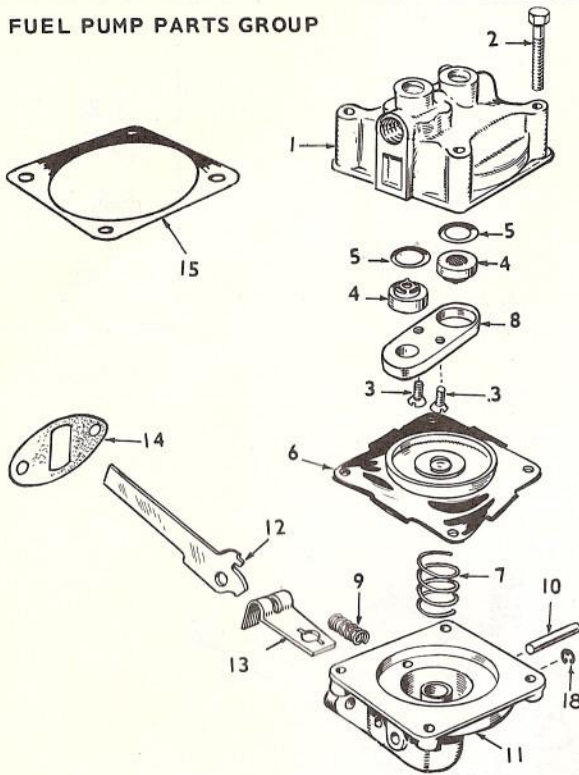

REF. NO.	PART NO.	QTY. USED	PART DESCRIPTION
	149D1251	1	Pump, Fuel - Complete
	149K526	1	Repair Kit, Fuel Pump - Includes Parts Marked * Separately)
1			Body, Upper (Not Sold Separately)
2	815-148	4	Screw, Body (#3-32 x 7/8" HH)
3	815-147	2	Screw, Retainer - Phillips Flat Head (#6-32 x 5/8")
4	149-96	2	*Valve and Cage
5	149A95	2	*Gasket, Valve
6	149A582	1	*Diaphragm Assy.
7	149A672	1	Spring, Diaphragm
8	149A539	1	Retainer, Valve Cage
9	149A675	1	*Spring, Rocker Arm
10	516A113	1	Pin, Rocker Arm
11			Body, Lower (Not Sold Separately)
12	149A1148	1	Arm, Rocker
13	149A670	1	Link, Rocker
14	149A3	2	*Gasket, Fuel Pump Mounting
15	149A858	1	Gasket, Diaphragm

\* - Included in 149K526 Repair Kit.

### CARBURETOR PARTS GROUP

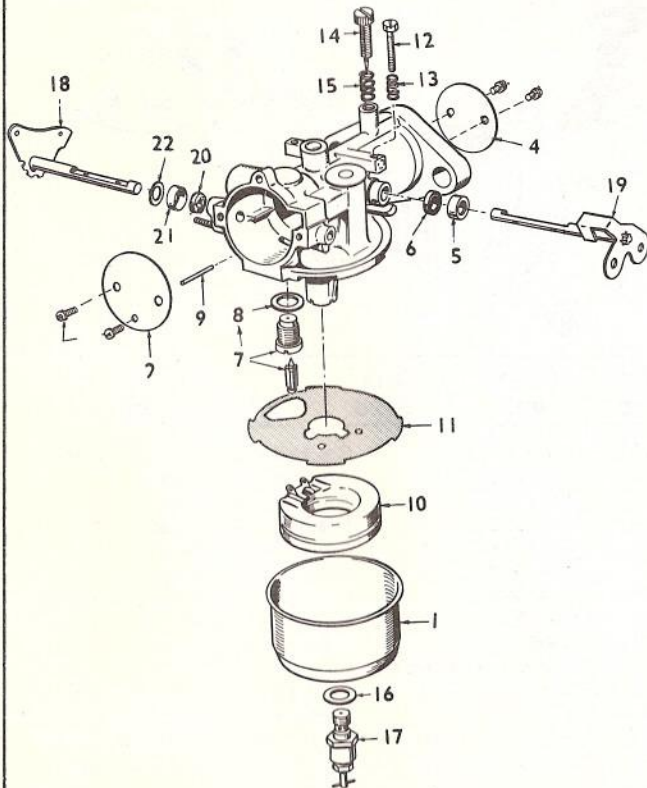

REF. NO.	PART NO.	QTY. USED	PART DESCRIPTION
	CARBURETOR, GASOLINE		
	141D772	1	For NB-MS/1847A
	141D781	1	For NB-MS/1846A
	141K785	1	Repair Kit, Includes Parts Marked *
	141K748	1	*Gasket Kit, Includes Parts Marked £
	154A733	2	*£ Gasket, Carburetor Flange
1	141P708	1	Bowl, Fuel
2	PLATE, CHOKE		
	141P771	1	For NB-MS/1847A
	141P741	1	For NB-MS/1846A
3	141P698	4	Screw & Washer, Choke & Throttle Plate Mtg.
4	141P706	1	Plate, Throttle
5	141P705	1	*Retainer, Seal
6	141-661	1	*£ Seal, Rubber
7	141P704	1	*Valve Seat Assembly, Fuel
8	141P696	1	*£ Washer, Fuel Valve Seat
9	141P703	1	*Shaft, Float
10	141P702	1	Float Assembly
11	141P701	1	*£ Gasket, Bowl to Body
12	141P700	1	Screw, Throttle Stop
13	141P711	1	Spring, Throttle Stop
14	141P786	1	Needle, Idle Adjusting
15	141P710	1	Spring, Idle Needle
16	141A77	1	*£ Washer, Main Jet Assy.
17	141-712	1	Jet Assy., Main (Adjustable)
18	141P742	1	Shaft, Choke
19	141P709	1	Shaft & Lever, Throttle
20	141P697	1	Seal, Felt
21	141P203	1	Retainer, Felt Seal
22	141P699	1	Washer

\* - Parts contained in Repair Kit.  
£ - Parts contained in Gasket Kit.

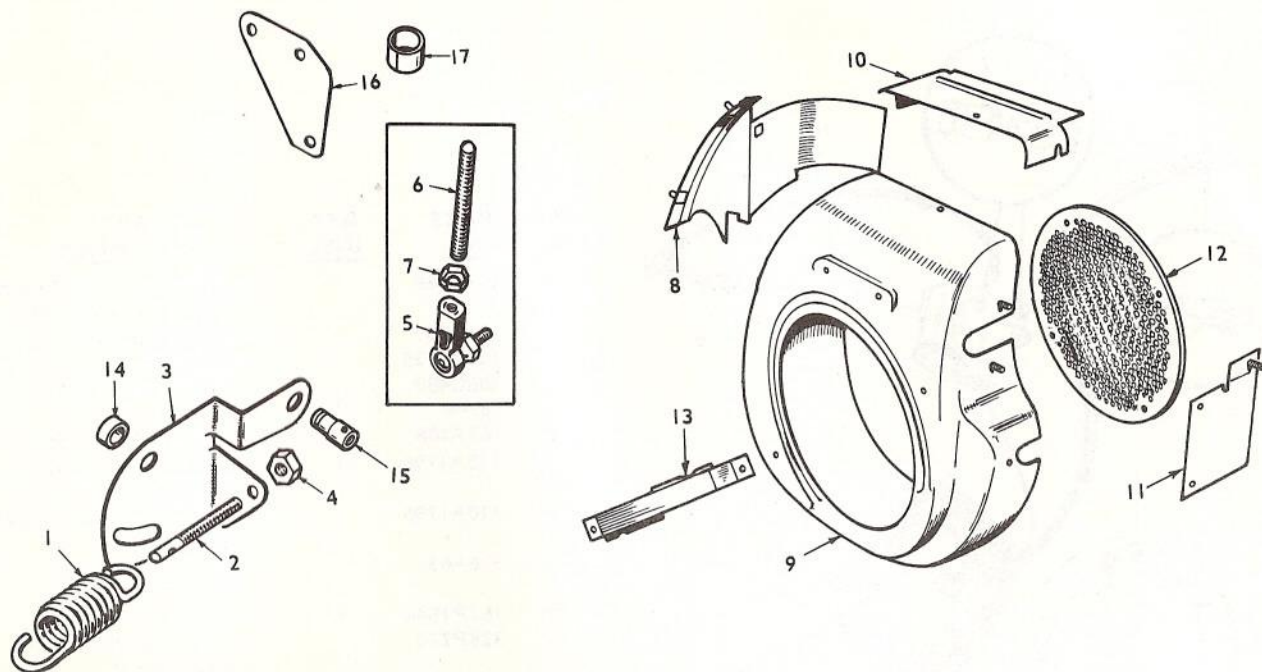

GOVERNOR AND HOUSING GROUP

REF. NO.	PART NO.	QTY. USED	PART DESCRIPTION
1	150A1044	1	Spring, Governor
2	150A96	1	Stud, Speed Adjusting
3	150B1270	1	Bracket, Speed Adjusting
4	870-131	1	Nut, Speed Adjusting
5	150A1081	2	Joint, Ball
6	150A883	1	Link, Throttle
7	870P188	2	Palnut, Locking
8	134C2045	1	Housing, Cylinder Air
9	134C2049	1	Housing, Blower

REF. NO.	PART NO.	QTY. USED	PART DESCRIPTION
10	134C2047	1	Cover, Cylinder Air
11	134B2046	1	Plate, Cylinder Air Housing
12	134A2048	1	Screen, Air Inlet
13	134B2040	1	Guard, Air Inlet
14	150A1269	2	Bushing, Governor Control Bracket
15	152A155	2	Swivel, Governor Control Arm
16	153A435	1	Bracket, Throttle and Choke
17	134A2100	1	Spacer, Cylinder Head to Cover



**IGNITION SYSTEM AND CHARGING  
ALTERNATOR GROUP**

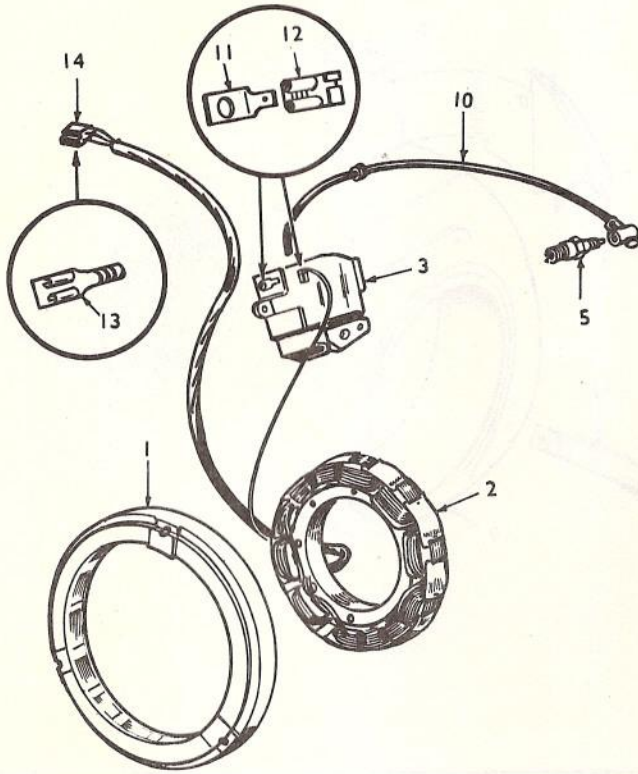

<u>REF. NO.</u>	<u>PART NO.</u>	<u>QTY. USED</u>	<u>PART DESCRIPTION</u>
1	191C768	1	Rotor, Ignition and Charge Mounted on Flywheel
2	191D769	1	Stator, Alternator
3	160C1125	1	Stator, Ignition
4	305C480	1	Regulator - Rectifier
5	167-4	1	Plug, Spark
6	167A188	1	Clip, Spark Plug Cable
7	110A1796	1	Gasket, Breaker Hole Cover (Early Models Only)
8	110A1795	1	Cover, Breaker Hole (Early Models Only)
9	526A63	2	Washer, Breaker Hole Cover (Early Models Only)
10	167P1546	1	Cable, Spark Plug
11	323P770	1	Terminal, Ignition Stator (Blade Type)
12	323P768	1	Terminal, Ignition Stator (Female)
13	323P767	3	Terminal, Tractor Connection
14	323P769	1	Body, Tractor Connection

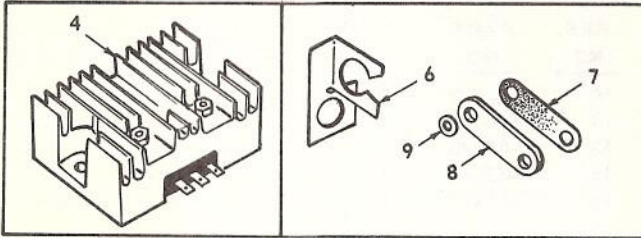

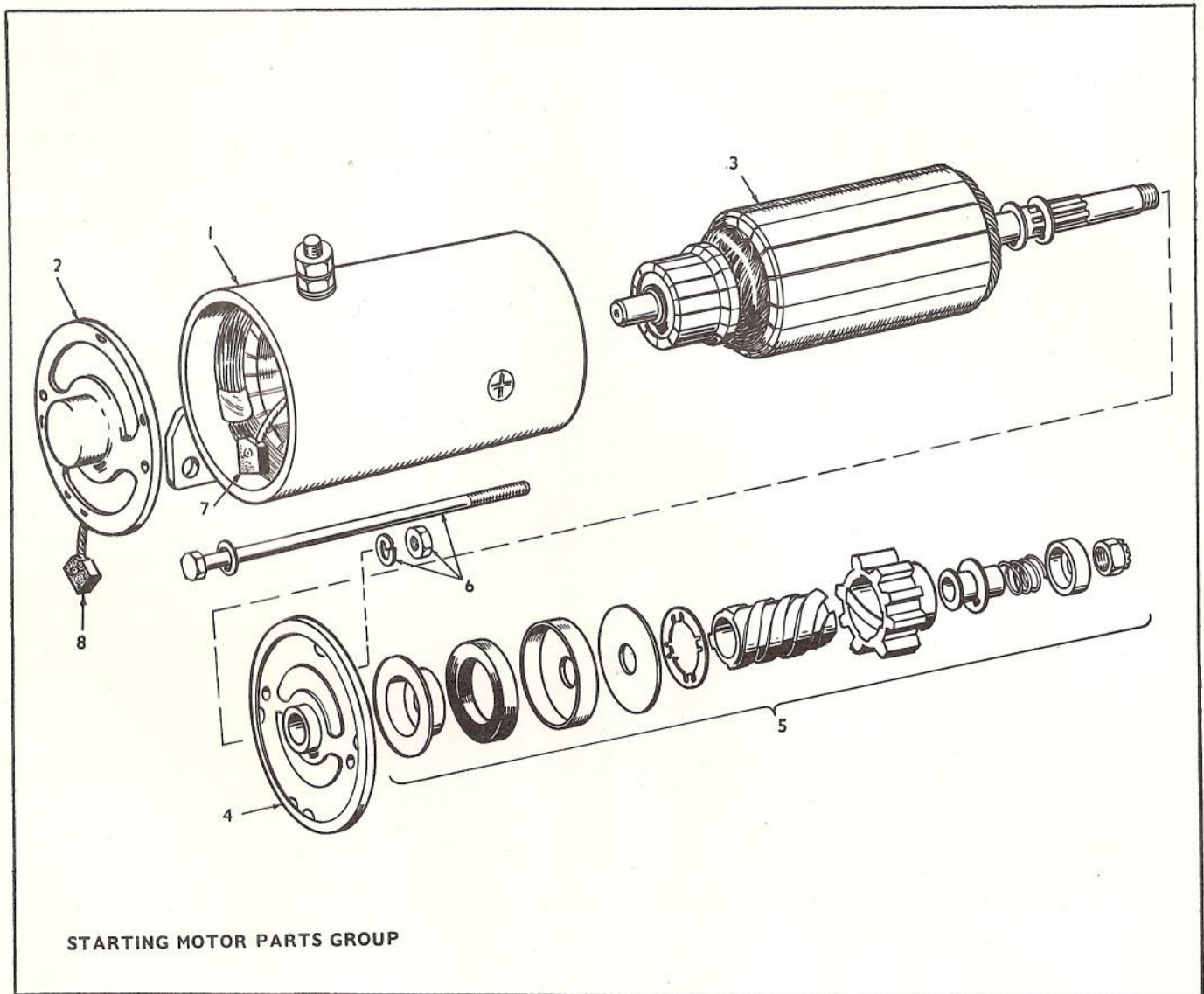

STARTING MOTOR PARTS GROUP

REF. NO.	PART NO.	QTY. USED	PART DESCRIPTION
	191C780	1	Motor, Starting
1	191-794	1	Housing Assembly
2	191-795	1	Cap Assembly, End
3	191-796	1	Armature Assembly
4	191-797	1	Cap Assembly, Drive End

REF. NO.	PART NO.	QTY. USED	PART DESCRIPTION
5	191-798	1	Drive Assembly, Complete
6	191-799	2	Bolt Assembly - Through
7	191-800	1	Brush, Positive
8	191-801	1	Brush, Negative

**SERVICE KITS**

NOTE: For other kits, refer to the group for the part in question.

168K114	1	Gasket Kit, Plant
522K255	1	Overhaul Kit, Engine